

EL-O-Matic E and P Series

Technical data pneumatic Rack and Pinion actuators

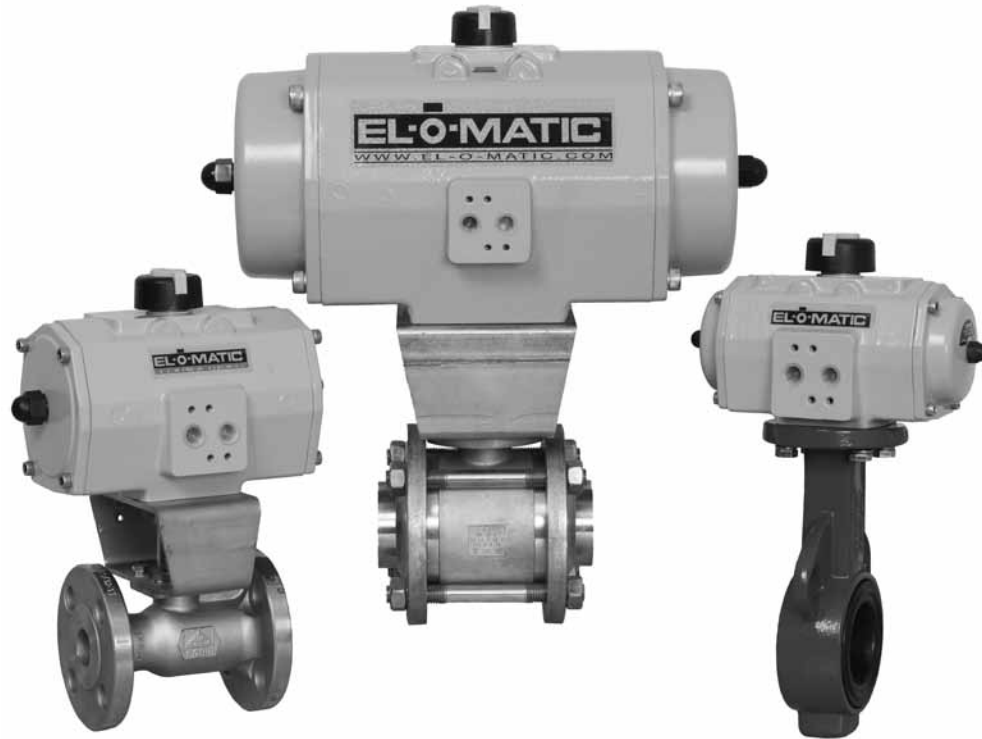

Data sheet

Sheet No.: A1.102 Rev. C

Date: January 2012

TECHNICAL DETAILS, STANDARD ACTUATOR

E/P

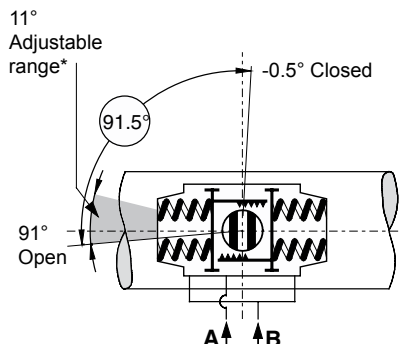
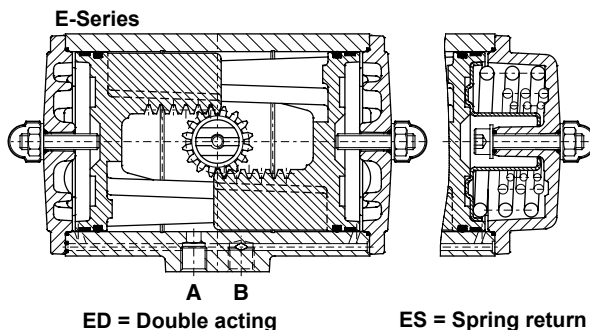
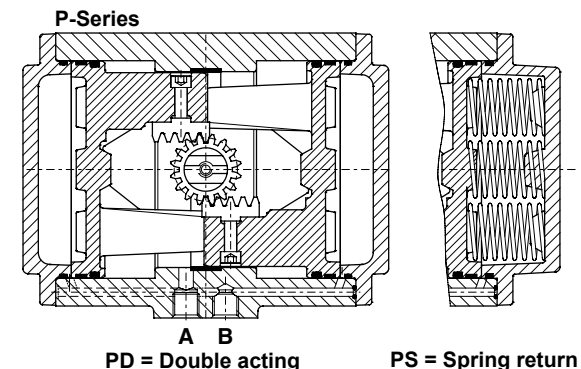

* only standard on E-Series actuators

Specification

Pressure range : Double acting 20 to 120 psi
 : Spring return 80 to 120 psi., with max. spring set 40 to 120 psi, reduced spring quantity

Torque : 180° actuators 87 psi maximum
 : 1133 to 40,000 in.lb at 80psi supply
 See torque data sheets 1.104.01 and 1.104.02

Operating media : Air, dry or lubricated and inert gasses
 : For sub-zero applications take appropriate measures

Temperature : -4° to +176°F

Lubrication : Factory lubricated for the normal life of the actuator

Construction : Suitable for indoor and outdoor installation

Finish : Polyester non-TGIC based powder coating (see data sheet A4.204.01)

Rotation : 91.5° (-0.5° CW to 91° CCW)

Double acting : Standard counter clockwise with port "A" pressurized (code A, see data sheet A1.503 for other assembly codes)

Spring return : Clockwise fail action (code A, see data sheet A1.504 for other assembly codes)

Limit stops : Standard on E-Series. Adjustable range 91°/80°
 : Optional on P-Series. See data sheet A1.501.01
 : For double stroke adjustment. See data sheet A1.501.05

European Directives

PED : All actuators are suitable for use with Group 2 gasses according to Pressure Equipment Directive 97/23/EC

ATEX : Optional : actuators suitable for use with Group 1 gasses
 : All basic actuators are suitable for use in hazardous area's classified II 2 GD, zones 1 or 2 (Gasses) and 21 or 22 (Dust)

Russian Approvals

EI-O-Matic E and P series pneumatic actuators are available with the GOST-R and Rostechnadzor (RTN) approvals.

Note

1. Operating time is average with actuator under load and solenoid valve fitted.
2. Air consumption is the actual free air volume at 1 atm.
3. Pressure is in barg.

ACTUATOR TYPE		E12	E25	E40	E65	E100	E150	E200	E350	E600	E950	E1600	P2500	P4000
Bore	inch	1.8	2.2	2.8	3.1	3.6	4.1	4.3	5.7	6.9	7.9	9.1	11.8	12.8
Stroke	inch	0.5	0.6	0.7	0.9	1.0	1.2	1.5	1.5	1.7	2.0	2.5	2.2	3.2
Weight:	Double acting	lb.	1.3	2.9	4.0	5.3	6.8	10.5	12.8	23	43	58	94	125
	Spring return	lb.	1.5	3.7	5.3	7.9	10.1	15.2	20.1	37	61	85	145	194
Operating time	sec.	0.4	0.5	0.7	1.1	1.2	1.8	2.3	3.6	4.5	5.4	6.9	7	12
Air consumption at 1 atm (cu./in.)	port A stroke	3.1	6.1	9.8	20	21	45	49	110	177	287	445	488	824
	port B stroke	3.7	6.7	13	22	30	40	61	116	189	299	488	568	1,068

EI-O-MATIC™

www.EI-O-matic.com

Copyright © Emerson Process Management. The information in this document is subject to change without notice.

Updated data sheets can be obtained from our website www.EI-O-Matic.com or from your nearest Valve Automation Center **USA:** +1 281 477 4100 **Europe:** +31 74 256 10 10 **Asia-Pacific:** +65 6501 4600



EMERSON™
 Process Management

Data sheet

Sheet No.: A1.102.10 Rev. D

Date: January 2012

EL-O-MATIC BASIC PNEUMATIC ACTUATOR CONFIGURATION

E/P

See following data sheets for more information

A1.104.01 / A1.104.02

A1.103.106 / A1.103.073 /
A1.103.102 / A1.103.103
A1.101.30 / A1.101.33 /
A4.204.01

A1.501.01/
A1.501.05

A1.503/
A1.504

A1.104.02

A1.103.073
A1.103.106
A1.103.120

A1.101.70 / A1.101.71

Single or Double action

ES or PS = Single acting, ED or PD = Double acting

Actuator size

E-Series
0012 = E12 **0025** = E25 **0040** = E40 **0065** = E65 **0100** = E100 **0150** = E150
0200 = E200 **0350** = E 350 **0600** = E600 **0950** = E950 **1600** = E1600

P-Series
2500 = P2500 **4000** = P4000

Valve flange

Metric ISO 5211	Metric DIN 3337	UNC/NPT ISO 5211	Finish
M =	D =	U =	Standard
N =	E =	V =	CSR coating ⁽²⁾ + Aluminum pinion
O =	F =	W =	CSR coating ⁽²⁾ + Stainless Steel pinion ⁽³⁾

Limit stops

0 = No limit stops
Standard on P-Series

1 = L1 One way limit stops
Standard on E-Series

2 = Double Stroke Adjustment
Standard on DSA-Series

Assembly code

Code	Action	Rotation	Mounting
A =	Spring to close	clock wise	in line with pipeline
B =	Spring to close	clock wise	across pipeline
C =	Spring to open	counter clock wise	across pipeline
D =	Spring to open	counter clock wise	in line with pipeline

Spring set E-Series

00 = Double acting actuator
01 = Springset 1 **04** = Springset 4
02 = Springset 2 **05** = Springset 5
03 = Springset 3 **06** = Springset 6

Spring set P-Series

00 = Double acting actuator
04 = Springset 4 **10** = Springset 10
06 = Springset 6 **12** = Springset 12
08 = Springset 8 **14** = Springset 14

Future expansion

A = Standard

Default Insert

Size (in mm.) ⁽¹⁾	E12	E25	E40	E65	E100	E150	E200	E 350	E600	E950	E1600	P2500	P4000
- ISO or UNC	00	11	14	14	19	19	22	27	27	36	46	00	00
- DIN	00	11	14	14	17	17	22	22	27	36	46	00	00

Visual Indication Code

D = Disk **K** = Knob **N** = No visual indication

Temperature range

0 = Standard TS: 80°C (176°F) -20°C (-4°F)
1 = High temp TS: 120°C (248°F) -20°C (-4°F)
2 = Low temp TS: 80°C (176°F) -40°C (-40°F)

⁽¹⁾ Actuators E12, P2500 and P4000 have no inserts. They have have a inner square the shaft
180° actuators are not covered by this configuration matrix.

⁽²⁾ CSR Coating not possible in combination with Double Stroke Adjustment limit stops (DSA series).

⁽³⁾ Stainless Steel Pinion not possible in combination with Double Stroke Adjustment limit stops (DSA series).

ES 0040.M 1 A 05 A.14 N 1



www.El-O-matic.com

Copyright © Emerson Process Management. The information in this document is subject to change without notice.

Updated data sheets can be obtained from our website www.El-O-Matic.com or from your nearest Valve Automation Center **USA:** +1 281 477 4100 **Europe:** +31 74 256 10 10 **Asia-Pacific:** +65 6501 4600



EMERSON
Process Management

Data sheet

Sheet No.: A1.501.01 Rev. B

Date: January 2012

EL-O-MATIC ACTUATOR WITH ONE WAY LIMIT STOPS

L1/LF

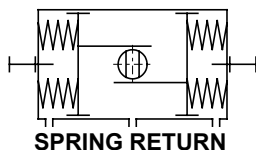
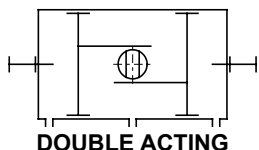

Dim. in inch	ACTUATOR TYPE	
	P2500	P4000
A	22.8	27.9
B	31.3	45.4
C	14.0	15
D	1.2	1.2

Description

Actuators with one way adjustable limit stops are used where the maximum opening (or closing) position of the valve needs to be reduced. For instance to adjust the maximum capacity of a remote operated valve.

Also actuators with 180° rotation are available with these stops.

Operation

Stop screws are fitted to both endcaps and the screw length is such that adjustment is possible through the specified rotation of the actuator.

The modified endcap is machined for -0.5° to +93° rotation for all P-Series models.

Identification

"L1" is added to the basic part number i.e. PD2500-L1

Specification:

Pressure	: Up to 120 PSI
Media	: Air, dry or lubricated or non-corrosive gas
Torque (90°)	: Data sheet A1.104.01 - A1.104.04
(180°)	: Data sheet P-Series A1.204.01 and A1.204.02
Other dimensions	: Data sheet A 1.103.XXX (90°)
	: Data sheet A 1.203.011 (180°)
Temperature	: -4.0° to +176°F
Adjustable range	: 80°-93°(90°) or 160°-186° (180°)

Adjustable position (see data sheet A1.503 or A1.504)

code	position
A	Valve open (spring to close)
B	Valve open (spring to close)
C	Valve closed (spring to open)
D	Valve closed (spring to open)

Note:

- 1) Can be provided with extra long screws for full range adjustment (identification: PD2500-LF)
- 2) This option in combination of a manual override gearbox is redundant

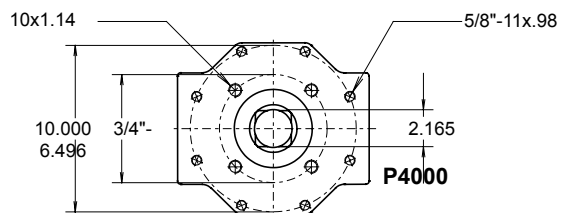
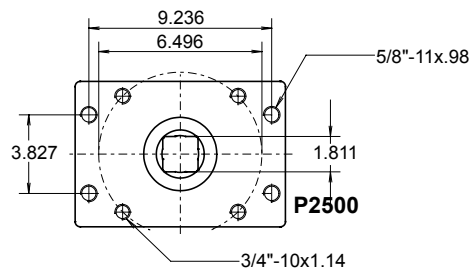
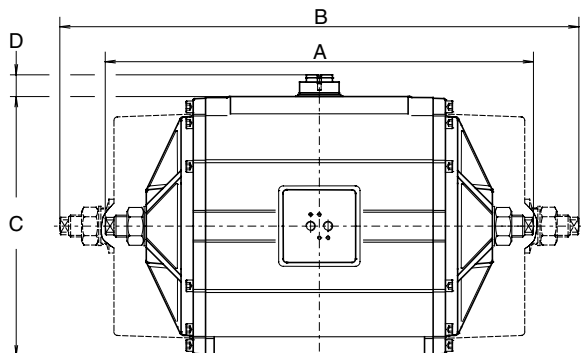

Note: Do not adjust under pressure

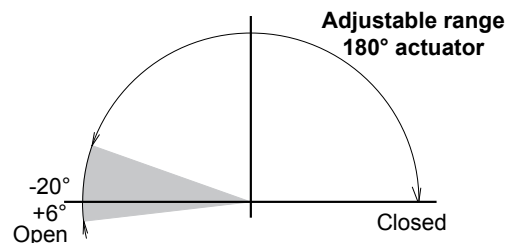
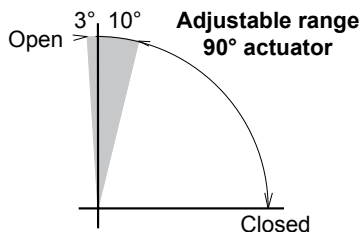

EL-O-MATIC™

www.El-O-matic.com

Copyright © Emerson Process Management. The information in this document is subject to change without notice.

Updated data sheets can be obtained from our website www.El-O-Matic.com or from your nearest Valve Automation Center **USA:** +1 281 477 4100 **Europe:** +31 74 256 10 10 **Asia-Pacific:** +65 6501 4600



EMERSON™
Process Management

Data sheet

Sheet No.: A1.501.03 Rev. B

Date: June 2013

LIMIT STOP PLATE DIMENSIONS

LS 420

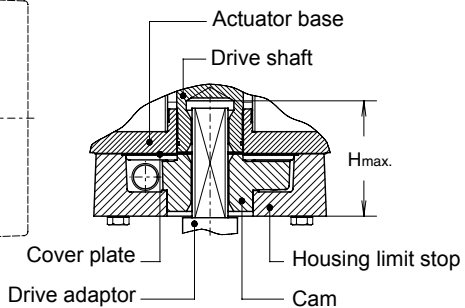
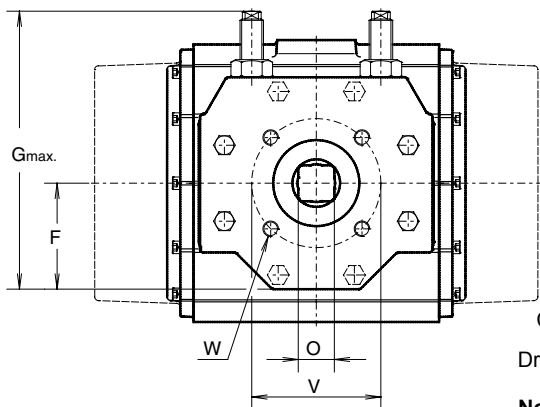
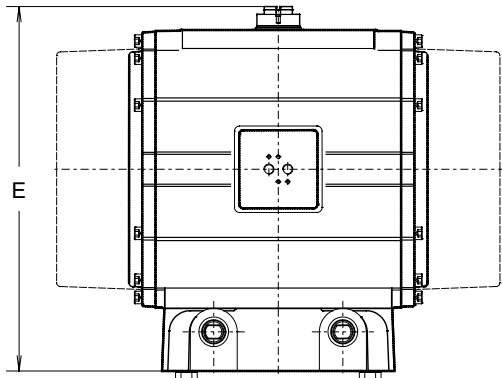

Note: Cover plate only in combination with P2500

Description

These limit stop plates are used when precise control is required for both end of stroke positions. It is possible to adjust 15° of both ends of the standard stroke.

Construction

The complete stop plate assembly may be added to the 90° P- series actuators. The assembly is normally sandwiched between the actuator and mounting surface of the valve or bracket. Bearing rings are used at both surfaces to provide a long life expectancy.

The unit is assembled with a drive adaptor which passes through the stop plate, into the square actuator and provides the coupling between the two components. This drive adaptor normally also accommodates the coupling of the valve stem.

Identification

"LS420" is added to the basic part number i.e. PD2500-LS420

Other dimensions

See data sheet A1.103.xxx

Option

Version for 180° or DIN-standard actuator

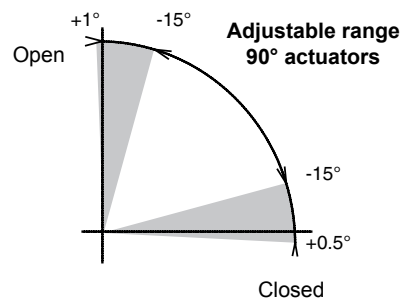

Dim. in inches	ACTUATOR TYPE	
	P2500	P4000
E	18.3	19.3
F	5.3	5.3
G	12.7	12.7
H	5.1	5.6
O	1.8	2.2
V	165	165
W	3/4-10 x 1.14"	3/4-10 x 1.14"

EL-O-MATIC™

www.El-O-matic.com

Copyright © Emerson Process Management. The information in this document is subject to change without notice.

Updated data sheets can be obtained from our website www.El-O-Matic.com or from your nearest Valve Automation Center **USA:** +1 281 477 4100 **Europe:** +31 74 256 10 10 **Asia-Pacific:** +65 6501 4600



EMERSON™
Process Management

Data sheet

Sheet No.: A1.501.05 Rev. B

Date: June 2013

EL-O-MATIC ACTUATOR WITH DOUBLE STROKE ADJUSTMENT

DSA

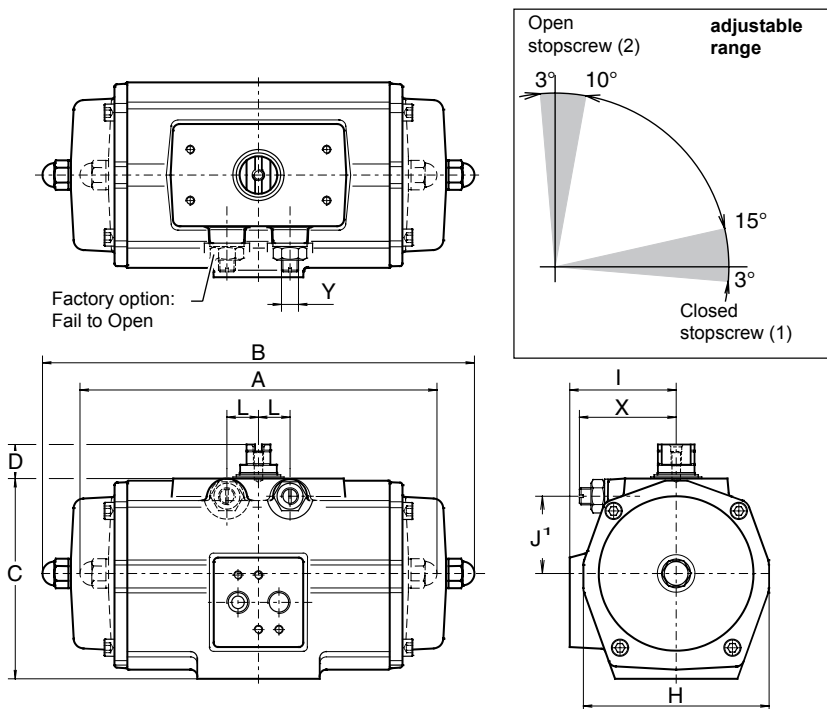

Description

Actuators with double stroke adjustment are normally used for high performance butterfly valves where a fine adjustment is required for the closed position. In this version adjustment is provided at the end of the opening and closing stroke positions. DSA actuators may be double acting or spring return, though are normally used as spring return (fail close) actuators.

Operation

The closed position is adjusted by means of the stop-screw (1) located in the actuator body and for the open position by the stop-screws (2) in the actuator end caps.

Identification

See data sheet A1.102.10

Specification

Pressure : Up to 120 psi
 Operating media : Air, dry or lubricated or non-corrosive gas
 Torque (90°) : Data sheet A1.104.01 - A1.104.02
 Rotation -
 - Spring return : Clock-wise on air failure.
 - Double acting : Counter clock-wise with port "A" pressurised.
 Other dimensions : Data sheet A1.103.XXX
 Temperature : -4° to +176° F
 Adjustable range : Closed position (1), -3° - 15°
 Open position (2), 80° - 93°

Note

- 1) Can be provided with extra long end-cap stop screws for full range adjustment of the "open" position.
- 2) This DSA option is not required on actuators fitted with manual override gearboxes, as MO gearboxes already incorporate this function.

Important

- 1) "Fail open" is factory option.
- 2) When a standard Fail to Close actuator is re-assembled for "Fail to Open" operation (code D; see data sheet 1.504), both stop-screws (1) and (2) will adjust the closed position. There is no adjustment for the open position!
- 3) Vice versa: When a Fail to Open actuator is re-assembled for "Fail to Close" operation (code A; see data sheet 1.504), both stop-screws (1) and (2) will adjust the open position. There is no adjustment for the closed position!

Dim. in inch.	Actuator type									
	E25	E40	E65	E100	E150	E200	E350	E600	E950	E1600
A DA	6.26	7.09	7.83	8.70	10.00	11.14	12.01	15.35	17.32	20.47
B SR	6.77	8.03	9.80	10.51	12.20	14.17	15.24	18.90	20.94	25.24
C	3.15	3.66	4.13	4.65	5.51	5.63	7.13	8.66	10.20	11.69
D	0.79	0.79	0.79	0.79	0.79	0.79	0.79	1.18	1.18	1.18
H	2.91	3.39	3.86	4.25	4.76	5.04	6.81	8.15	9.09	264.00
I	1.81	2.01	2.26	2.48	2.76	2.87	3.71	4.45	4.96	5.59
J1	1.11	1.38	1.57	1.72	1.92	2.12	2.85	3.50	4.03	4.50
L	0.45	0.61	0.61	0.73	0.97	0.97	0.97	1.63	1.63	1.87
Y	1/4"-20	5/16"-18	5/16"-19	3/8"-16	3/8"-16	1/2"-13	1/2"-13	5/8"-11	5/8"-11	3/4"-10
X	1.42	1.63	1.63	1.99	2.36	2.46	2.85	4.02	4.02	4.31
X max.	1.63	1.91	1.91	2.30	2.64	2.91	3.31	4.51	4.51	4.88

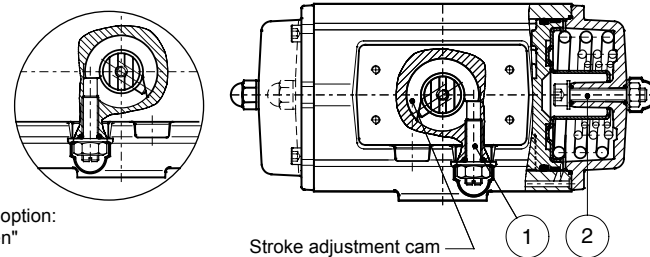

EL-O-MATIC™

www.El-O-matic.com

Copyright © Emerson Process Management. The information in this document is subject to change without notice.

Updated data sheets can be obtained from our website www.El-O-Matic.com or from your nearest Valve Automation Center **USA:** +1 281 477 4100 **Europe:** +31 74 256 10 10 **Asia-Pacific:** +65 6501 4600

EMERSON™
 Process Management

Data sheet

Sheet No.: A1.103.106 Rev. F

Date: September 2013

DIMENSION SHEET STANDARD ACTUATOR - ISO

E/P

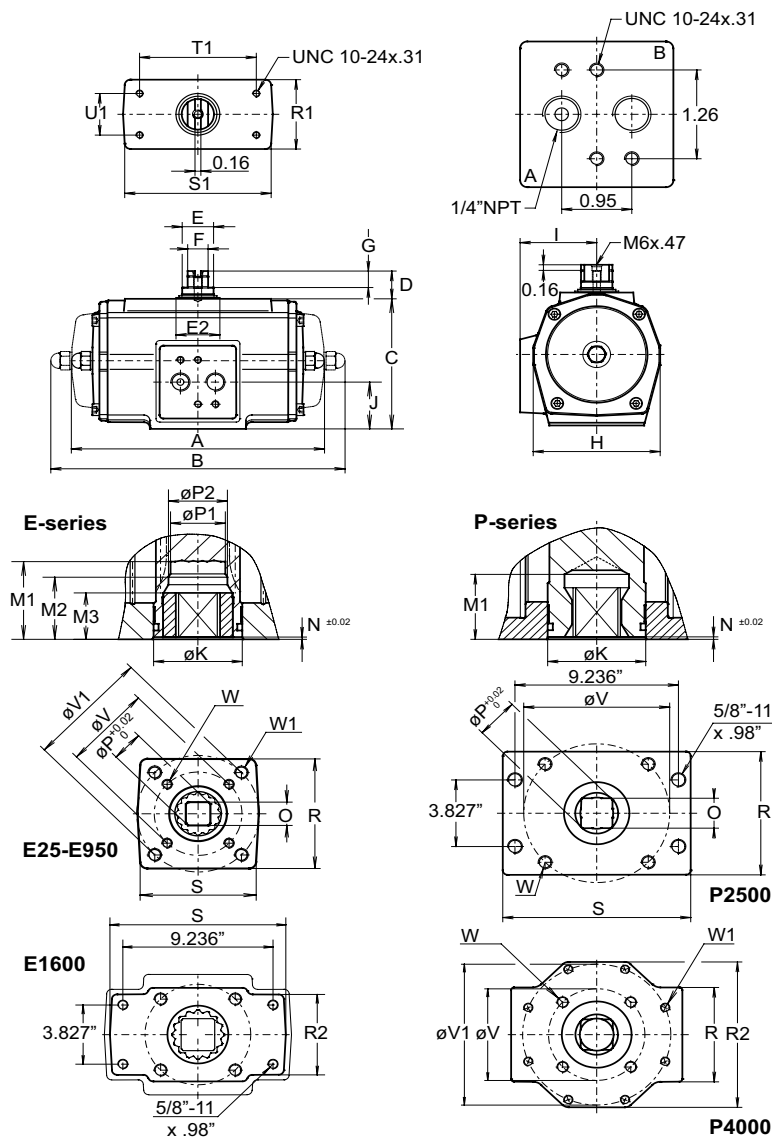

Dim. in inch	Actuators E-series										P-series	
	E 12	E 25	E 40	E 65	E100	E150	E200	E 350	E600	E950	E1600	P2500
A DA	6.26	7.09	7.83	8.70	10.00	11.14	12.01	15.24	16.69	20.31	14.88	19.76
B SR	6.77	8.03	9.80	10.51	12.20	14.17	15.24	18.78	20.35	25.08	22.44	32.83
C	3.15	3.66	4.13	4.65	5.51	5.63	7.13	8.66	10.20	11.69	14.02	14.96
D	0.79	0.79	0.79	0.79	0.79	0.79	0.79	1.18	1.18	1.18	1.18	1.18
E	0.63	0.87	0.87	0.87	1.42	1.42	1.42	2.17	2.17	2.52	2.17	2.52
E2	0.91	1.18	1.18	1.18	1.77	1.77	1.77	2.56	2.56	2.95	2.56	3.15
F	0.39	0.55	0.55	0.55	0.75	0.75	0.75	1.42	1.42	1.42	1.42	1.42
G	0.47	0.47	0.47	0.47	0.47	0.47	0.47	0.39	0.39	0.39	0.39	0.39
H	2.91	3.39	3.86	4.25	4.76	5.04	6.81	8.15	9.09	10.43	13.78	14.96
I	1.81	2.09	2.26	2.48	2.76	2.87	3.71	4.45	4.96	5.59	7.28	7.87
J	1.26	1.32	1.54	1.59	1.59	1.99	2.85	3.33	4.15	4.74	7.01	7.48
K	0.94	1.30	1.30	1.50	2.17	2.17	2.17	2.68	2.95	3.74	3.35	4.72
M1	1.36	1.36	1.36	1.36	1.97	1.97	1.97	2.05	2.52	3.23	2.60	3.03
M2	-	-	-	-	1.06	-	1.46	1.46	-	-	-	-
M3	0.669	0.669	0.669	0.787	0.787	1.161	1.161	1.161	1.949	2.303	-	-
N	0.04	0.04	0.04	0.06	0.04	0.06	0.06	0.06	0.06	0.06	0.12	0.06
O max.	0.437	0.556	0.556	0.753	0.753	0.871	1.068	1.068	1.424	1.817	1.817	2.173
O min.	0.433	0.551	0.551	0.748	0.748	0.866	1.063	1.063	1.417	1.811	1.811	2.165
P	0.555	0.713	0.713	0.992	1.110	1.110	1.425	1.425	1.898	2.370	2.370	2.843
P1	0.555	0.713	0.831	0.909	1.303	1.303	1.303	1.437	1.909	2.382	-	-
P2	-	-	-	0.988	1.264	1.264	1.264	-	-	-	-	-
R	2.05	2.56	2.76	2.76	3.39	3.54	4.49	4.88	5.12	6.06	6.69	6.69
R1	1.97	1.97	1.97	2.36	2.36	2.36	2.36	3.54	3.54	4.92	6.30	6.30
R2	-	-	-	-	-	-	-	-	-	5.20	-	10.31
S	2.05	2.56	2.76	2.76	3.62	3.54	4.49	4.88	5.59	11.02	11.42	11.42
S1	3.94	3.94	3.94	3.94	3.94	3.94	3.94	6.69	6.69	8.27	9.65	9.65
T1	3.150	3.150	3.150	3.150	3.150	3.150	3.150	5.118	5.118	5.118	5.118	5.118
U1	1.181	1.181	1.181	1.181	1.181	1.181	1.181	1.181	1.181	1.181	1.181	1.181
V	1.417	1.969	1.969	1.969	2.756	2.756	2.756	4.016	4.016	6.496	6.496	6.496
W	10-24 x.31"	1/4"-20 x.39"	1/4"-20 x.39"	1/4"-20 x.39"	5/16"-18 x.39"	5/16"-18 x.39"	5/16"-18 x.39"	3/8"-16 x.63"	3/8"-16 x.63"	3/4"-10 x1.14"	3/4"-10 x1.14"	3/4"-10 x1.14"
V1	1.969	2.756	2.756	2.756	4.016	4.016	4.016	4.921	5.512	-	-	10.000
W1	1/4"-20 x.39"	5/16"-18 x.39"	5/16"-18 x.39"	5/16"-18 x.39"	3/8"-16 x.63"	3/8"-16 x.63"	3/8"-16 x.63"	1/2"-13 x.79"	5/8"-11 x.98"	-	-	5/8"-11 x.98"

For E12 dimensions see data sheet A1.103.102

Note

1. Flange and square drive to ISO 5211
2. Top and solenoid flange to VDI/VDE 3845 (NAMUR)
3. For P-series actuators with limit stops see A1.501.01

EL-O-MATIC™

www.El-O-matic.com

Copyright © Emerson Process Management. The information in this document is subject to change without notice.

Updated data sheets can be obtained from our website www.El-O-Matic.com or from your nearest Valve Automation Center **USA:** +1 281 477 4100 **Europe:** +31 74 256 10 10 **Asia-Pacific:** +65 6501 4600



EMERSON™
Process Management

Data sheet

Sheet No.: A1.103.102 Rev. A

Date: November 2009

DIMENSION SHEET ACTUATOR ISO E12 (90°/180°)

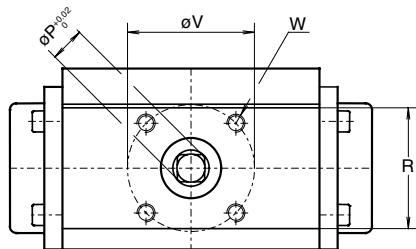
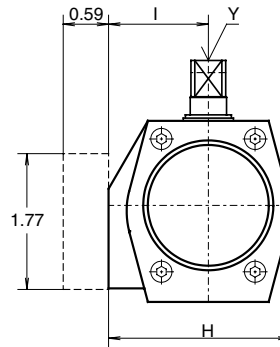
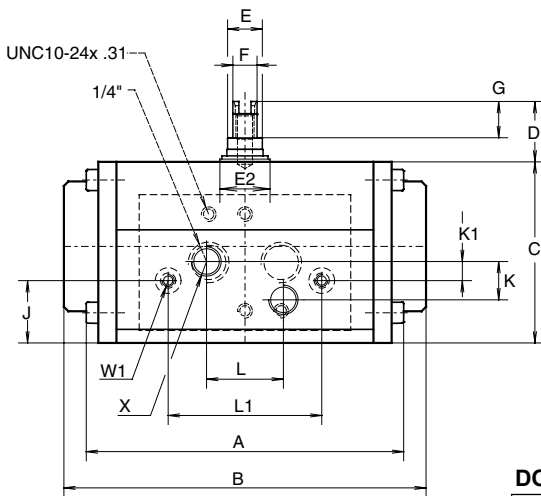
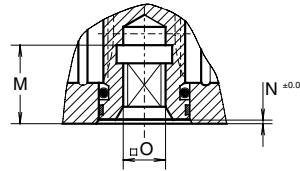
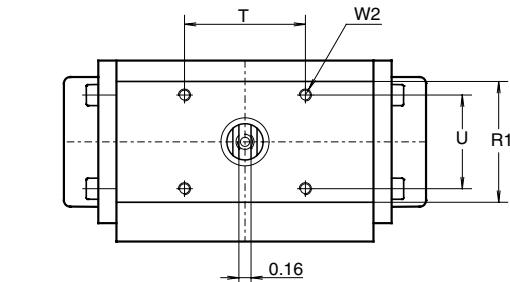

DOUBLE ACTING TORQUE (ED)

Pressure	psi	40	50	60	70	80	90	100	120
Torque 90°/180°	(in.lb.)	59	74	89	104	119	134	149	179

SINGLE ACTING TORQUE (ES)

Pressure	psi	Air stroke						Spring stroke	
		60		80		100		start	end
Position	-	start	end	start	end	start	end	start	end
Torque 90°	(in.lb.)	48	23	80	55	112	87	64	41
Torque 180°	(in.lb.)	49	25	81	57	112	88	63	40

Dim. in Inches	90°	180°
A ED	4.06	6.10
B ES	4.65	8.50
C	2.36	2.36
D	0.79	0.79
E	0.63	0.63
E2	0.91	0.91
F	0.39	0.39
G	0.47	0.47
H	2.36	2.36
I	1.30	1.30
J	0.83	0.83
K	0.50	0.50
K1	0.25	0.25
L	1.00	1.00
L1	2.00	2.00
M	0.65	0.65
N	0.039	0.039
Omax.	0.358	0.358
Omin.	0.354	0.354
P	0.476	0.476
R	1.57	1.57
R1	1.57	1.57
T	1.57	1.57
U	1.22	1.22
V	1.654	1.654
W	10-24 UNCx.24"	10-24 UNCx.24"
W1	10-24 UNCx.24"	10-24 UNCx.24"
W2	10-24 UNCx.24"	10-24 UNCx.24"
X	1/8"NPT	1/8"NPT
Y	M6x.48	M6x.48



www.El-O-matic.com

Copyright © Emerson Process Management. The information in this document is subject to change without notice.

Updated data sheets can be obtained from our website www.El-O-Matic.com or from your nearest Valve Automation Center **USA:** +1 281 477 4100 **Europe:** +31 74 256 10 10 **Asia-Pacific:** +65 6501 4600



EMERSON
Process Management

Data sheet

Sheet No.: A1.103.200 Rev. C

Date: August 2011

DRIVE INSERTS FOR EL-O-MATIC ACTUATORS

E

Standard available insert shapes

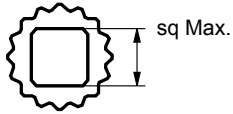

Optional available insert shapes

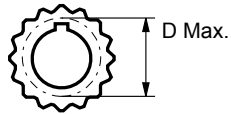
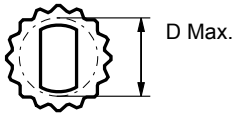

Insert mounting acc. ISO 5211

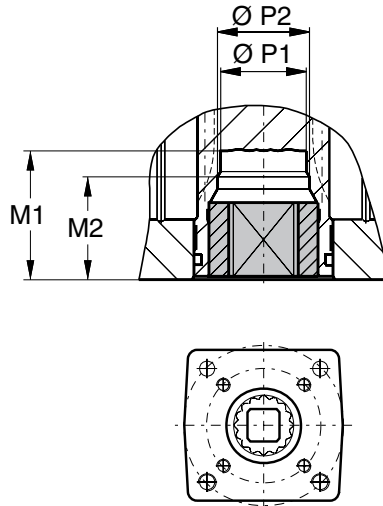

Description

Most of the El-O-Matic actuators are fitted with drive inserts. This enables actuators to be directly mounted onto suitable valves and eliminates the need for a bracket and coupling type mounting kit. The use of direct mounts significantly cuts the cost of the valve/actuator assembly.

Standard actuators are fitted with square drive inserts in accordance with ISO 5211 (or DIN 3337), but a wide variety of other inserts are also available. Special inserts may have oversize or undersize squares, double-D and shaft key way forms.

Drive inserts can be supplied on factory built actuators or as loose items and are easily replaceable at distributor or end user level.

Where direct mounts are not possible, for instance on valves with exposed grand packing, the use of inserts often simplifies the design of the mounting kit.

Material : Aluminum alloy
Finish : Anodized

The following actuator types do not have inserts.

- E12,
- P2500 and P4000
- 180° actuators

These actuators have inner square directly in the bottom of the pinion. See the following data sheets for more information :

E12	ISO5211	A1.103.102
P2500/P4000	ISO 5211	A1.103.106
180°	ISO 5211	A1.203.011

Standard inserts with inner-square-dimensions per actuator type									
	E25	E40 / E65	E100	E150	E200	E350	E600	E950	E1600
	0.433	0.551	0.748	0.748	0.866	1.063	1.063	1.417	1.811
Optional insert dimensions									
	0.354	0.394	0.472	0.551	0.551	0.551	0.551	0.866	
	0.394	0.472	0.551	0.630	0.630	0.630	0.630		
			0.63	0.669	0.669	0.669	0.669		
				0.866	0.748	0.748	0.748		
				0.945	0.945	0.866	0.866		
				1.063	1.063	0.945	0.945		
Maximum insert dimensions									
M1	1.36	1.36	1.36	1.97	1.97	1.97	2.05	2.52	3.23
M2	-	-	1.06	1.46	1.46	1.46	-	-	-
P1	0.71	0.71	0.91	1.26	1.26	1.26	1.44	1.91	2.38
P2	-	-	0.99	1.43	1.43	1.43	-	-	-
SQ max.	0.630	0.630	0.748	1.063	1.063	1.063	1.063	1.417	1.811
D max.	0.827	0.827	0.929	1.323	1.323	1.323	1.323	1.772	2.362

EL-O-MATIC™

www.El-O-matic.com

Copyright © Emerson Process Management. The information in this document is subject to change without notice.

Updated data sheets can be obtained from our website www.El-O-Matic.com or from your nearest Valve Automation Center **USA:** +1 281 477 4100 **Europe:** +31 74 256 10 10 **Asia-Pacific:** +65 6501 4600



EMERSON™
Process Management

Data sheet

Sheet No.: A1.104.01 Rev. B

Date: January 2010

DOUBLE ACTING ACTUATOR TORQUE (In.lb.)

90°

DOUBLE ACTING TORQUE

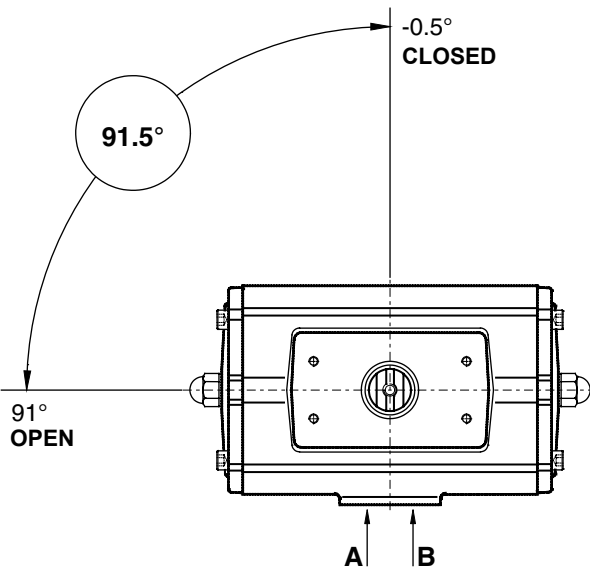
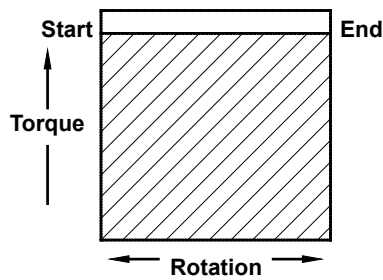

Actuator	Torque of double acting actuators (in In.lb) Supply pressure (psi)														
	Type	Size	30	35	40	45	50	55	60	70	75	80	90	100	120
ED	12		43.9	51.4	58.9	66.4	73.9	81.4	88.9	104	111	119	134	149	179
ED	25		81.4	95.3	109	123	137	151	165	193	206	220	248	276	332
ED	40		153	179	205	231	257	283	309	361	387	413	466	518	622
ED	65		233	272	312	352	392	431	471	551	590	630	709	789	948
ED	100		344	402	461	520	578	637	696	813	872	930	1048	1165	1400
ED	150		551	645	739	833	927	1021	1115	1303	1397	1491	1680	1868	2244
ED	200		754	883	1011	1140	1269	1398	1527	1784	1913	2042	2299	2557	3072
ED	350		1310	1534	1757	1981	2205	2428	2652	3100	3323	3547	3994	4442	5337
ED	600		2226	2606	2986	3366	3747	4127	4507	5267	5647	6028	6788	7548	9069
ED	950		3323	3890	4458	5025	5593	6160	6728	7862	8430	8997	10132	11267	13537
ED	1600		5493	6431	7369	8307	9245	10183	11121	12998	13936	14874	16750	18626	22379
PD	2500		8774	10273	11825	13270	14768	16267	17847	20858	22363	23869	26880	29891	35912
PD	4000		14874	17414	19962	22495	25035	27576	30127	35210	37751	40293	45375	50458	60623

Note

- Emerson Process Management recommends that the valve manufacturer supply the maximum required torque values (Including any adjustments or suggested safety factors for valve service conditions or application). Additionally, the valve manufacturer must identify at which position(s) and direction(s) of rotation (Counter Clock Wise or Clock Wise) these maximum requirements occur.
- If in doubt, or you require any assistance with sizing actuators, do not hesitate to contact your nearest Emerson's Valve Automation Division representative.
- Pressure on port "A" opens the actuator*
- The actuator is shown in closed position*

(* code A, data sheet A1.503)

EL-O-MATIC™

www.El-O-matic.com

Copyright © Emerson Process Management. The information in this document is subject to change without notice.

Updated data sheets can be obtained from our website www.El-O-Matic.com or from your nearest Valve Automation Center **USA:** +1 281 477 4100 **Europe:** +31 74 256 10 10 **Asia-Pacific:** +65 6501 4600



EMERSON™
Process Management

Data sheet

Sheet No.: A1.101.33 Rev. B

Date: January 2012

CONSTRUCTION, PARTS AND MATERIALS E-SERIES ACTUATORS

E

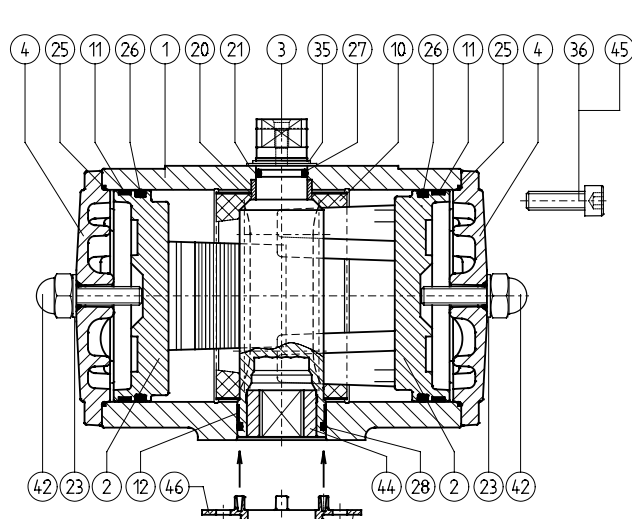

Optional center-plate

Notes

- 1 Hard anodized aluminum alloy: AlZnMgCu1.5, DIN 1725/1
- 2 Deltatone Coating
- 3 Anodized
- 4 Zinc plated and passivated
- 5 CSR Coating (see 4.204.02)
- 6 Stainless Steel Sandvic 1802, SS2382
- 7 Stainless Steel X35CrM017
- 8 No insert, adaptor square direct in pinion

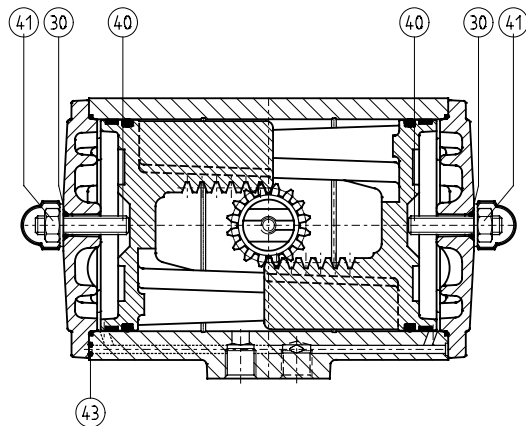

DOUBLE ACTING ED

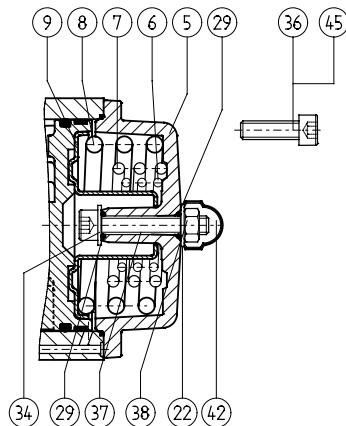

SINGLE ACTING ES

Parts			Materials		Executions		
Nr.	Description	Qty.	Description	Specification	Std	S.S. Shaft	CSR
1	Body	1	Aluminum Alloy	UNS A13600, ASTM B85	-	-	5
2	Piston	2	Aluminum Alloy	UNS A03560, ASTM B26	-	-	-
3	Drive pinion	1	GAISI10Mg, DIN 1725/2	UNS 1 77075, ASTM 7075 T6	1	6	6
4	End Cap ED	2	Aluminum Alloy	UNS A13600, ASTM B85	-	-	5
5	End Cap ES	2	Aluminum Alloy	UNS A13600, ASTM B85	-	-	5
6	Spring- inner	2	Carbon Spring Steel	UNS G10860, ASTM A228	2	2	2
7	Spring- mid	2	Carbon Spring Steel	UNS G10860, ASTM A228	2	2	2
8	Spring- outer	2	Carbon Spring Steel	UNS G10860, ASTM A228	2	2	2
9	Spring Holder	2	Steel	C45, DIN 17200	3	3	3
10	* Guide Band	1	Nylatron	PA6.6 + MoS2	-	-	-
11	* Guide Band	2	PTFE, Carbon filled	PTFE + 25% C	-	-	-
12	* Bearing Bush	1	Nylatron	PA6.6 + MoS2	-	-	-
20	* Bearing Bush	1	Delrin	POM	-	-	-
21	* O-ring	1	Nitrile Rubber	Buna N	-	-	-
22	* Washer ES	2	Nylon	PA6	-	-	-
23	* Washer ED	2	Nylon	PA6	-	-	-
25	* O-ring	2	Nitrile Rubber	Buna N	-	-	-
26	* O-ring	2	Nitrile Rubber	Buna N	-	-	-
27	* Washer	1	ZEDEX 100 K	-	-	-	-
28	* O-ring	1	Nitrile Rubber	Buna N	-	-	-
29	* O-ring	4	Nitrile Rubber	Buna N	-	-	-
30	* O-ring	2	Nitrile Rubber	Buna N	-	-	-
34	Washer ES	2	Steel	C35	3	3	3
35	* Spring Clip	1	Carbon Spring Steel	MIL - R-212 48B	2	7	7
36	End Cap Bolt ED/ES	8	Stainless Steel	AISI 304	-	-	-
37	Limit Stop Bolt ES	2	Stainless Steel	AISI 304	-	-	-
38	Nut	2	Stainless Steel	AISI 304	-	-	-
40	Limit Stop Bolt ED	2	Stainless Steel	AISI 304	-	-	-
41	Nut	2	Stainless Steel	AISI 304	-	-	-
42	Nut Cover	2	Polyethylene	PE	-	-	-
43	* O-ring	2	Nitrile Rubber	Buna N	-	-	-
44	Insert	1	Aluminum Alloy	UNS 1 6082, ASTM 6082	4	9	4
45	Threaded insert	8	Steel	UNS G10430, ASTM A29	3	3	3

* Recommended spare parts (contained in Repair kits)

Remark

All materials are European origin, listed are the nearest US equivalents.

Finish

Standard : Polyester non-TGIC based powder coating
(see data sheet A4.204.01)

CSR : CSR Coating (see data sheet A4.204.02)



www.El-O-matic.com

Copyright © Emerson Process Management. The information in this document is subject to change without notice.

Updated data sheets can be obtained from our website www.El-O-Matic.com or from your nearest Valve Automation Center **USA:** +1 281 477 4100 **Europe:** +31 74 256 10 10 **Asia-Pacific:** +65 6501 4600



EMERSON
Process Management

Data sheet

Sheet No.: A1.101.30 Rev. B

Date: January 2012

CONSTRUCTION, PARTS AND MATERIALS P-SERIES ACTUATORS

P

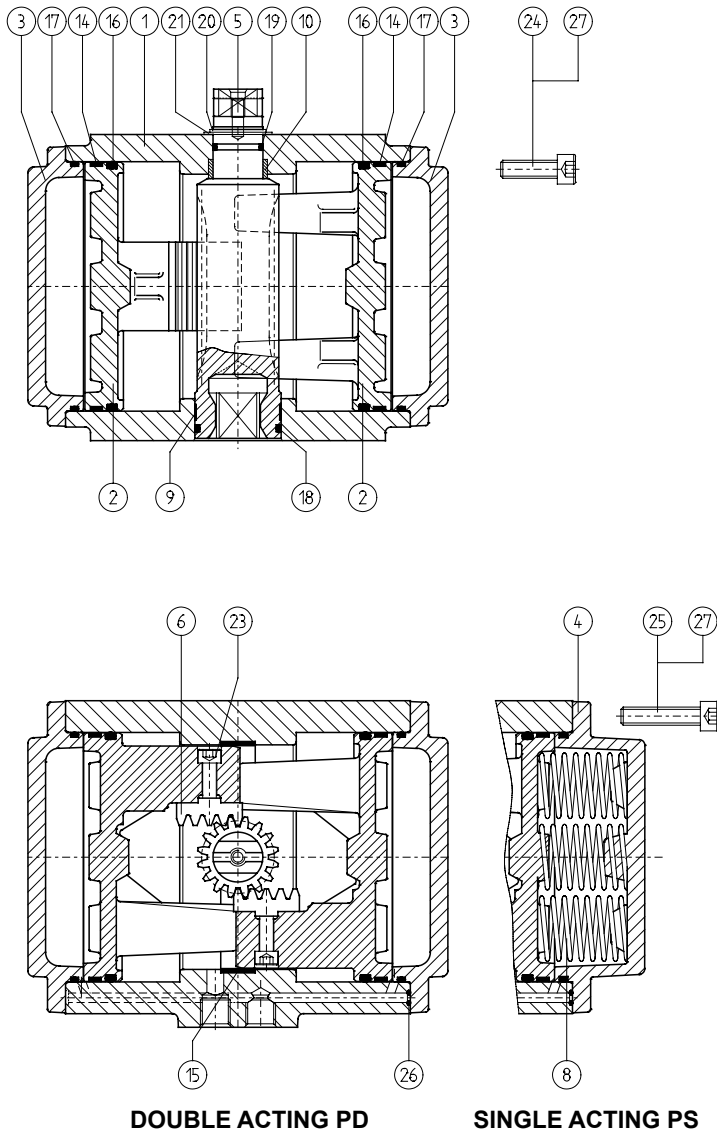

Parts			Materials		Executions		
Nr.	Description	Qty.	Description	Specification	Std	S.S. Shaft	CSR
1	Body	1	Aluminum Alloy	UNS A13600, ASTM B85	-	-	6
2	Piston	2	Aluminum Alloy	UNS A03560, ASTM B26	-	-	-
3	Endcap PDA	2	Aluminum Alloy	UNS A13600, ASTM B85	-	-	6
4	Endcap PSA	2	Aluminum Alloy	UNS A13600, ASTM B85	-	-	6
5	Drive pinion	1	Aluminum Alloy	UNS 1 77075, ASTM 7075 T6	1	4	4
6	Gear Rack	2	Steel	UNS G10950, ASTM A108	-	-	-
8	Spring	14	Carbon Spring Steel	UNS G10860, ASTM A228	2	2	2
9	* Bearing Bush	1	Nylatron GS	PA6.6 + MoS2	-	-	-
10	* Bearing Bush	1	Delrin	POM	-	-	-
14	* Guide band	2	PTFE, Carbon filled	PTFE + 25% C	-	-	-
15	* Guide band	2	PTFE, Carbon filled	PTFE + 25% C	-	-	-
16	* O-ring	2	Nitrile Rubber	Buna N	-	-	-
17	* O-ring	2	Nitrile Rubber	Buna N	-	-	-
18	* O-ring	1	Nitrile Rubber	Buna N	-	-	-
19	* O-ring	1	Nitrile Rubber	Buna N	-	-	-
20	* Spring Clip	1	Carbon Spring Steel	MIL - R-212 48B	2	5	5
21	* Thrust Washer	1	ZEDEX 100 K	-	-	-	-
23	Bolt	4	Alloy Steel	12.9 ASTM F568	-	-	-
24	Endcap bolt PDA	20	Alloy Steel	8.8 ASTM F568	2	4	4
25	Endcap bolt PSA	20	Alloy Steel	8.8 ASTM F568	2	4	4
26	* O-ring	2	Nitrile Rubber	Buna N	-	-	-
27	Threaded insert	20	Steel	UNS G10430, ASTM A29	3	3	3

* Recommended spare parts (contained in Repair kit)

Notes

- 1 Hard anodized
- 2 Deltatone® Coating
- 3 Zinc plated and passivated
- 4 Stainless Steel AISI 304
- 5 Stainless Steel, X35CrM017
- 6 CSR Coating (see A4.204.02)
- 7 P4000 has a stainless steel (AISI 304) locking ring between spring clip (20) and thrust washer (21)
- 8 P4000 has in the springs a guiding bush (PVC)

Remark

All materials are European origin, listed are the nearest US equivalents

Finish

- Standard : Polyester non-TGIC based powder coating (see data sheet A4.204.01)
- CSR : CSR Coating (see data sheet A4.204.02)

EL-O-MATIC™

www.El-O-matic.com

Copyright © Emerson Process Management. The information in this document is subject to change without notice.

Updated data sheets can be obtained from our website www.El-O-Matic.com or from your nearest Valve Automation Center **USA:** +1 281 477 4100 **Europe:** +31 74 256 10 10 **Asia-Pacific:** +65 6501 4600

EMERSON™
Process Management

Data sheet

Sheet No.: A1.101.60 Rev. B

Date: January 2012

CONSTRUCTION, PARTS AND MATERIALS DSA ACTUATOR

DSA

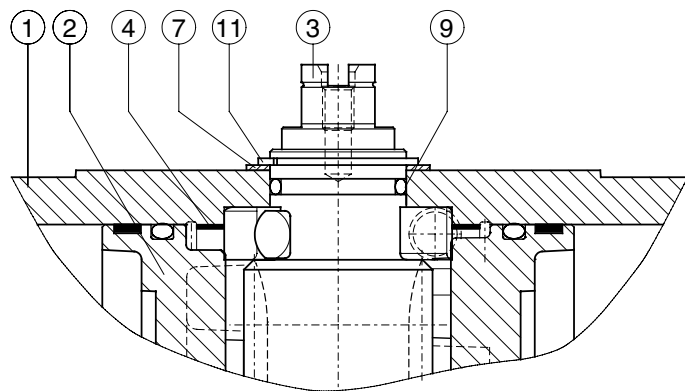
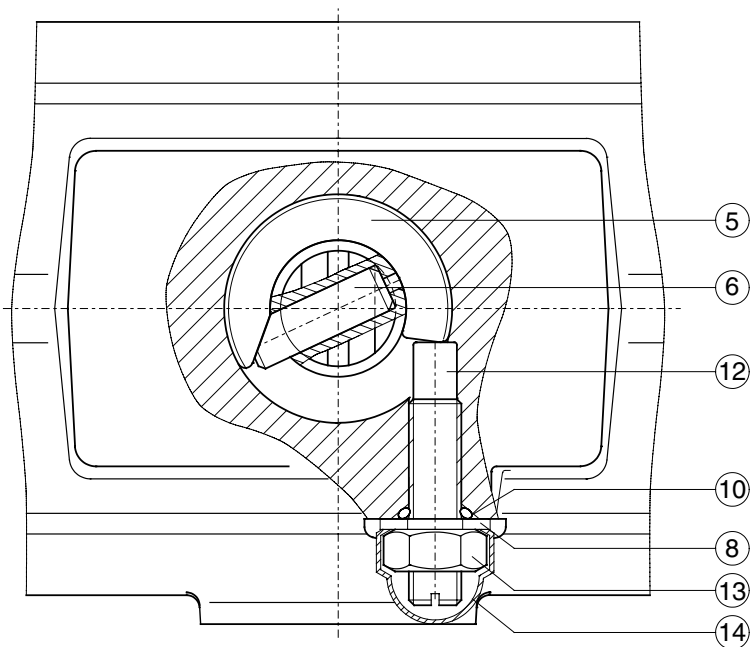

Nr.	Description	Qty.	Material	Specification	Note
1	Body DSA	1	Aluminum Alloy	UNS A13600, ASTM B85	-
2	Piston DSA	2	Aluminum Alloy	UNS A03560, ASTM B26	-
3	Drive pinion DSA	1	Aluminum Alloy	AlZnMgCu1.5, DIN 1725/1	1
4	* Guide Band DSA	1	Nylatron GS	UNS A13600, ASTM B85	-
5	Cam for stroke adj. DSA	1	Stainless Steel	UNS A13600, ASTM B85	-
6	Shaftpin for stroke adj. DSA	1	Chrome nickel steel	UNS G10860, ASTM A228	-
7	* Washer	1	ZEDEX 100 K	-	-
8	* Washer	1	Nylon	UNS G10860, ASTM A228	-
9	* O-ring shaft top	1	Nitrile Rubber	C45, DIN 17200	-
10	* O-ring limit stop bolt DSA	1	Nitrile Rubber	PA6.6 + MoS2	-
11	Circlip	1	Carbon spring steel	PTFE + 25% C	2
12	Limitstop bolt DSA	1	Stainless Steel	PA6.6 + MoS2	-
13	Nut	1	Stainless Steel	POM	-
14	Nut Cover	1	Polyethylene	Buna N	-

* Recommended spare parts (contained in Repair kits DSA)

Finish

Polyester non-TGIC based powder coating (see data sheet A4.204.01)

Note

- 1 Hard anodized
- 2 Deltatone® coating

Remark

This data sheet shows only the extra or specific parts of a DSA actuator.
For all the other parts see data sheet A1.101.33

EL-O-MATIC™

www.El-O-matic.com

Copyright © Emerson Process Management. The information in this document is subject to change without notice.

Updated data sheets can be obtained from our website www.El-O-Matic.com or from your nearest Valve Automation Center **USA:** +1 281 477 4100 **Europe:** +31 74 256 10 10 **Asia-Pacific:** +65 6501 4600



EMERSON™
Process Management

Data sheet

Sheet No.: A1.101.70 Rev. D

Date: January 2012

LOW TEMPERATURE ACTUATOR SPECIFICATIONS

-40°C / +80°C

-40°F / +176°F

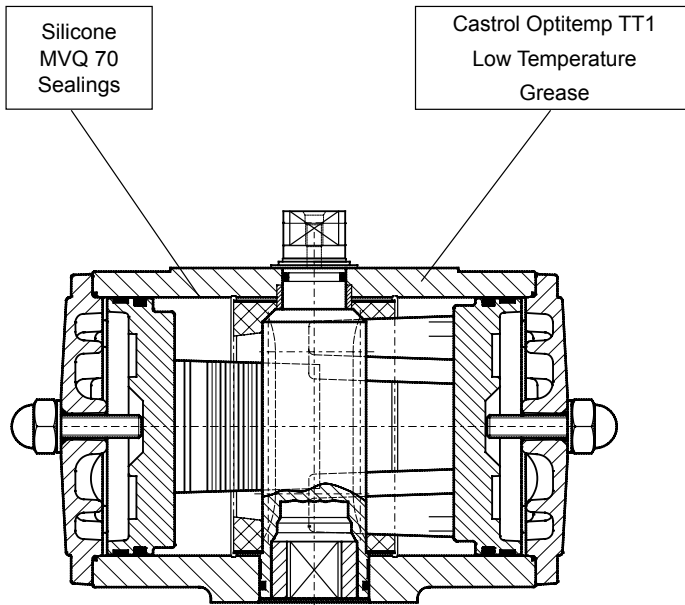

Description

A double piston, rack and pinion pneumatic actuator incorporating a three point piston support system, anti-blowout spindle and with high duty synthetic bearings at all bearing points.

This version is a standard aluminum actuator, but incorporating parts and materials suitable for low temperature operation.

Note

When operating actuators in sub-zero temperatures (< 0°C or < 32°F) care should be taken to counter the effects of freezing condensate inside the actuator.

Specification

Max. pressure : 120 psi (8 bar)

Torque : Standard

Media : Air or non corrosive gas

Temperature : -40°F to +176°F (-40°C to +80°C)

Finish : Polyester non-TGIC based powder coating (see data sheet A4.204.01)

Spare parts

Dedicated low temperature spare parts are available for maintenance or make a standard actuator suitable for low temperature operation.

Materials				
Part	Material		Specifications	Remark
Housing	Aluminum Alloy		UNS A13600, ASTM B85	
Drive Shaft	Aluminum Alloy		UNS 1 77075, ASTM 7075 T6	Hard anodized
	Steel (180° rotation)		ETG100 or 42CrMo4V XM	Zinc Plated type > P750
	Stainless Steel		Sandvic 1802, SS2382 or X35CrM017	type > E950
Piston	Aluminum Alloy		UNS A03560, ASTM B26	
Sealings	Silicone MVQ 70 O-rings		-/-	
Grease	Castrol Optitemp TT1		-/-	
Shaft bearings	Top :	Delrin	POM	
	Bottom :	Nylatron	PA6.6 + MoS2	
Piston bearings	PTFE		25% Carbon filled	
	PTFE ("P" series)		25% Carbon filled	
Body bearings	Nylatron ("E" series)		PA6.6 + MoS2	
	ZEDEX 100 K		-/-	
Shaft thrust washer	Stainless Steel ("E" series)		AISI 304 A2	
End cap bolts	Alloy Steel ("P" series)		8.8 DIN 912	Deltatone® coating
	Carbon Spring Steel		UNS G10860, ASTM A228	Deltatone® coating

EL-O-MATIC™

www.El-O-matic.com

Copyright © Emerson Process Management. The information in this document is subject to change without notice.

Updated data sheets can be obtained from our website www.El-O-Matic.com or from your nearest Valve Automation Center **USA:** +1 281 477 4100 **Europe:** +31 74 256 10 10 **Asia-Pacific:** +65 6501 4600



EMERSON™
Process Management

Data sheet

Sheet No.: A1.101.71 Rev. C

Date: January 2012

HIGH TEMPERATURE ACTUATOR SPECIFICATIONS

-20°C / +120°C

-4°F / +248°F

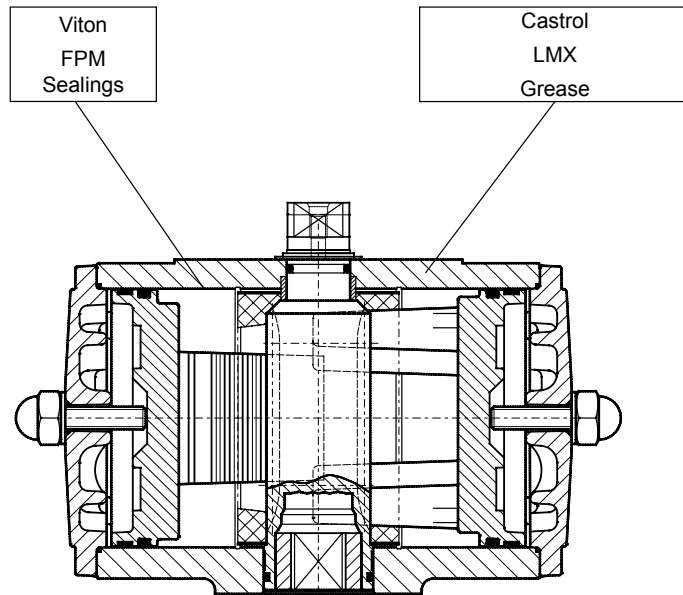

Description

A double piston, rack and pinion pneumatic actuator incorporating a three point piston support system, anti-blowout spindle and with high duty synthetic bearings at all bearing points.

This version is a standard aluminum actuator, but incorporating parts and materials suitable for low temperature operation.

Specification

Max. pressure : 120 psi (8 bar)

Torque : Standard

Media : Air or non corrosive gas

Temperature : -4°F to +248°F (-20°C to +120°C)

Finish : Polyester non-TGIC based powder coating (see data sheet A4.204.01)

Spare parts

Dedicated high temperature spare parts are available for maintenance or make a standard actuator suitable for low temperature operation.

Materials				
Part	Material		Specifications	Remark
Housing	Aluminum Alloy		UNS A13600, ASTM B85	
Drive Shaft	Aluminum Alloy		UNS 1 77075, ASTM 7075 T6	Hard anodized
	Steel (180° rotation)		ETG100 or 42CrMo4V XM	Zinc Plated type > P750
	Stainless Steel		Sandvic 1802, SS2382 or X35CrM017	type > E950
Piston	Aluminum Alloy		UNS A03560, ASTM B26	
Sealings	Viton FPM O-rings		-/-	
Grease	Castrol LMX		-/-	
Shaft bearings	Top :	Delrin	POM	
	Bottom :	Nylatron	PA6.6 + MoS2	
Piston bearings	PTFE		25% Carbon filled	
Body bearings	PTFE	("P" series)	25% Carbon filled	
	Nylatron	("E" series)	PA6.6 + MoS2	
Shaft thrust washer	ZEDEX 100 K		-/-	
End cap bolts	Stainless Steel	("E" series)	AISI 304 A2	
	Alloy Steel	("P" series)	8.8 DIN 912	Deltatone® coating
Springs	Carbon Spring Steel		UNS G10860, ASTM A228	Deltatone® coating



www.El-O-matic.com

Copyright © Emerson Process Management. The information in this document is subject to change without notice.

Updated data sheets can be obtained from our website www.El-O-Matic.com or from your nearest Valve Automation Center **USA:** +1 281 477 4100 **Europe:** +31 74 256 10 10 **Asia-Pacific:** +65 6501 4600



EMERSON
Process Management

Data sheet

Sheet No.: A4.201 Rev. A

Date: November 2009

INSTALLATION OF SPRINGS OF P-SERIES ACTUATOR

P

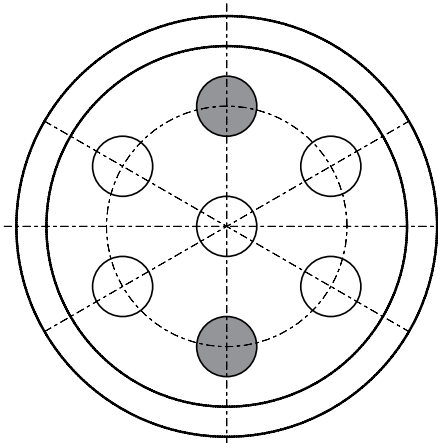

4 SPRINGS

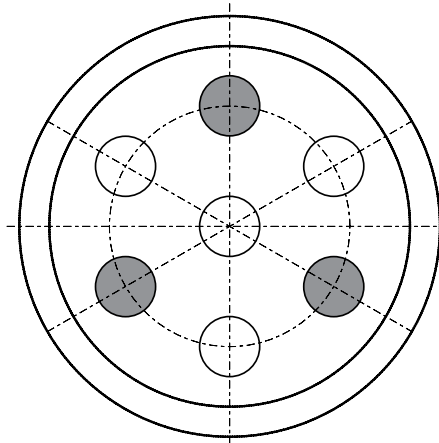

6 SPRINGS

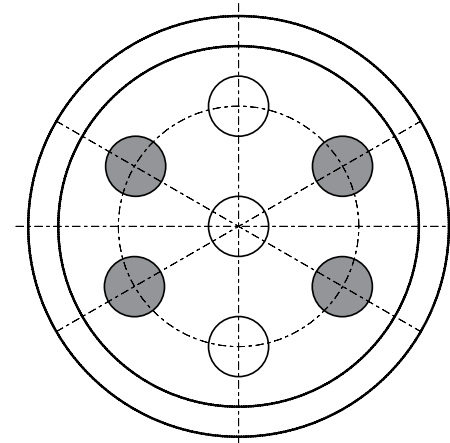

8 SPRINGS

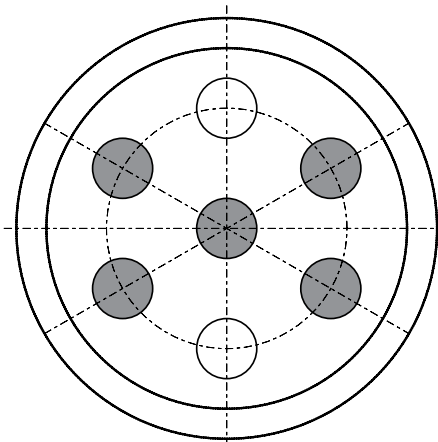

10 SPRINGS

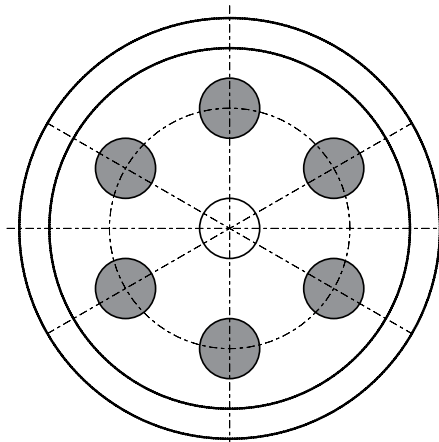

12 SPRINGS

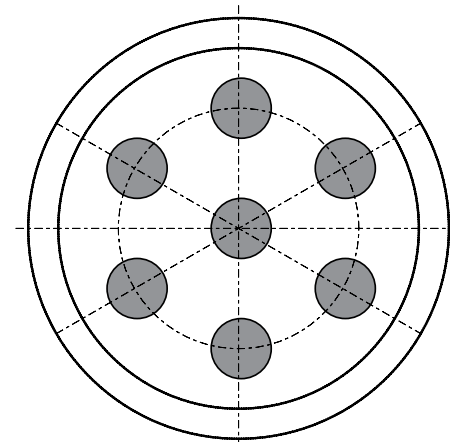

14 SPRINGS



EL-O-MATIC™

www.El-O-matic.com

Copyright © Emerson Process Management. The information in this document is subject to change without notice.

Updated data sheets can be obtained from our website www.El-O-Matic.com or from your nearest Valve Automation Center **USA:** +1 281 477 4100 **Europe:** +31 74 256 10 10 **Asia-Pacific:** +65 6501 4600



EMERSON™
Process Management

Data sheet

Sheet No.: A4.202 Rev. A

Date: November 2009

INSTALLATION OF SPRINGS OF E-SERIES ACTUATOR

E

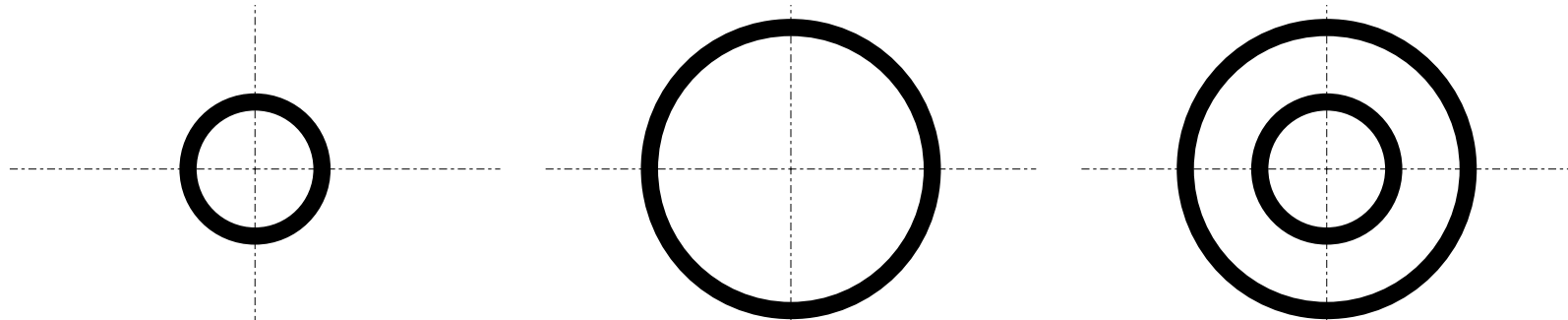

SPRING SET No. 1
inner spring

SPRING SET No. 2
mid spring

SPRING SET No. 3
inner spring
mid spring

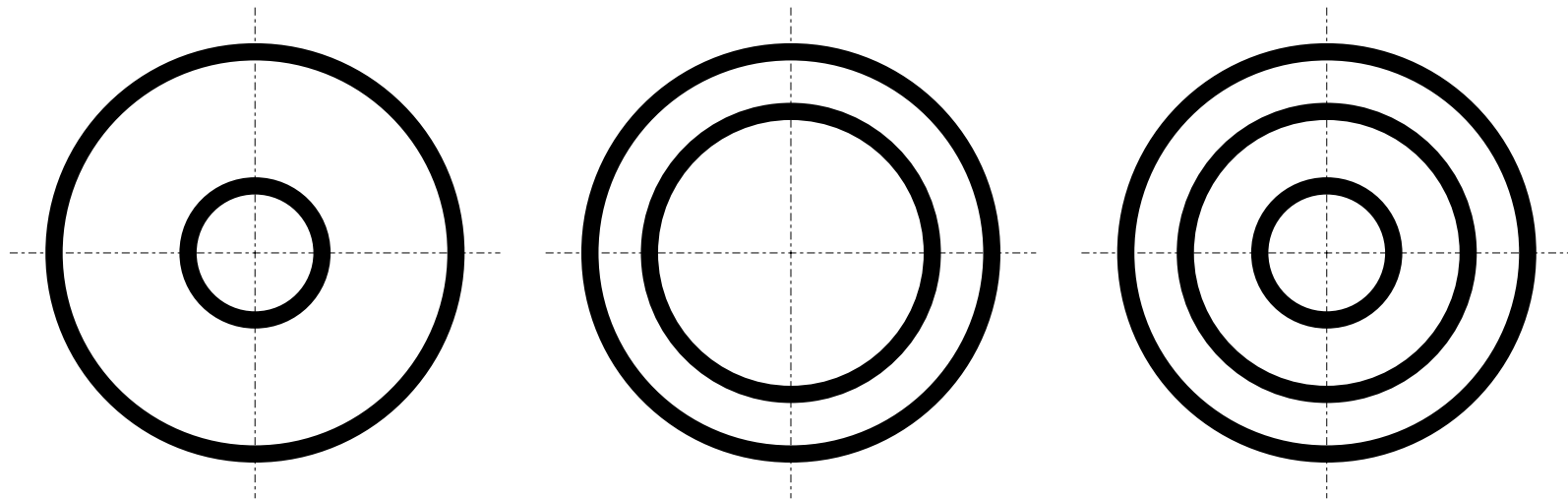

SPRING SET No. 4
inner spring
outer spring

SPRING SET No. 5
mid spring
outer spring

SPRING SET No. 6
inner spring
mid spring
outer spring



www.El-O-matic.com

Copyright © Emerson Process Management. The information in this document is subject to change without notice.

Updated data sheets can be obtained from our website www.El-O-Matic.com or from your nearest Valve Automation Center **USA:** +1 281 477 4100 **Europe:** +31 74 256 10 10 **Asia-Pacific:** +65 6501 4600



Data sheet

Sheet No.: A1.503 Rev. A

Date: November 2009

DOUBLE ACTING ACTUATOR ASSEMBLY MODES

E/P

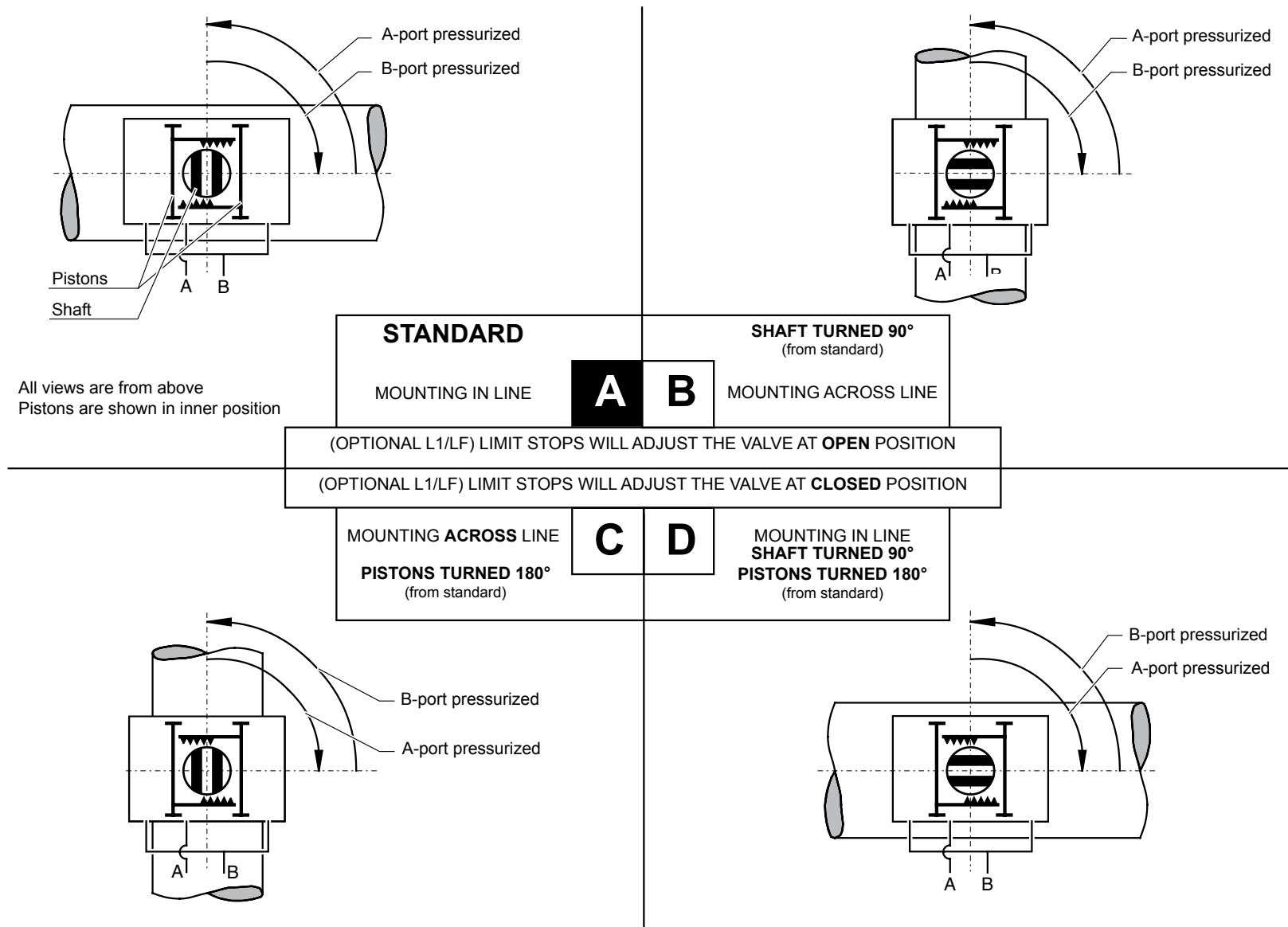

www.El-O-matic.com

Copyright © Emerson Process Management. The information in this document is subject to change without notice.

Updated data sheets can be obtained from our website www.El-O-Matic.com or from your nearest Valve Automation Center **USA:** +1 281 477 4100 **Europe:** +31 74 256 10 10 **Asia-Pacific:** +65 6501 4600



EMERSON
Process Management

Data sheet

Sheet No.: A1.504 Rev. A

Date: November 2009

SPRING RETURN ACTUATOR ASSEMBLY MODES

E/P

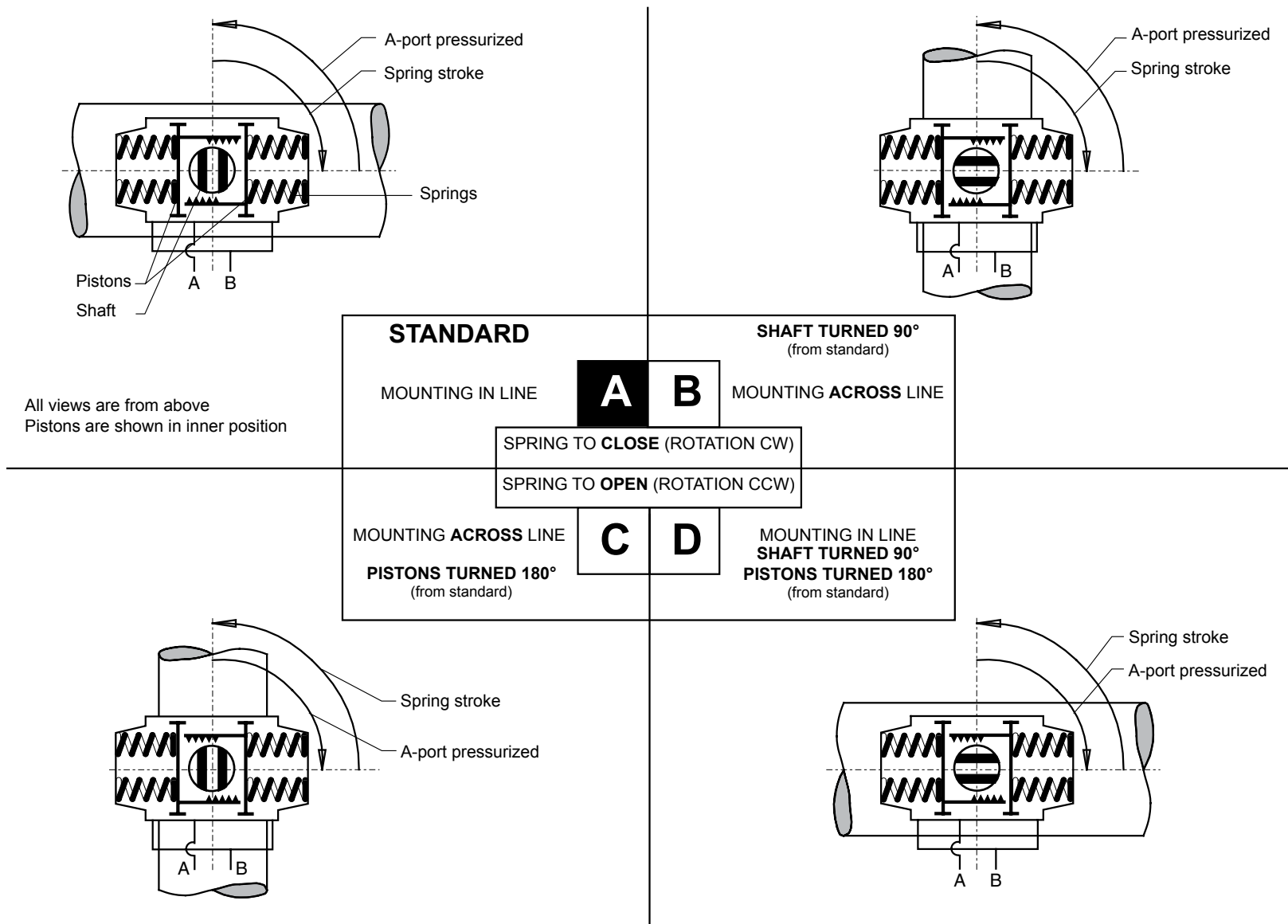

www.El-O-matic.com

Copyright © Emerson Process Management. The information in this document is subject to change without notice.

Updated data sheets can be obtained from our website www.El-O-Matic.com or from your nearest Valve Automation Center **USA:** +1 281 477 4100 **Europe:** +31 74 256 10 10 **Asia-Pacific:** +65 6501 4600



EMERSON
Process Management

Data sheet

Sheet No.: A4.204.01 Rev. B

Date: April 2011

EL-O-MATIC STANDARD CORROSION PROTECTION SYSTEM

Description

The corrosion protection system of standard EL-O-Matic E&P series pneumatic actuators consist of the following treatments or materials:

1 De-greasing

All aluminum parts are de-greased before the powder coating is applied by washing with an alkaline solution to assure the best bonding between the aluminum surface and the coating.

2 Powder coating

- Polyester non-TGIC based powder coating for exterior use.
- The powder coating is applied cold using automatic electrostatic spray equipment and is cured at minimum 190°C (374°F) offering excellent anti color fade and weather resistance.
- The powder coating thickness is 80µm (3.15 mils) minimum, and 160µm (6.3 mils) maximum.
- Good resistance against most chemical bases, acids, solvents, alkalis and oils at normal temperatures.
- Excellent exterior mechanical durability.
- The coating has passed a salt spray test according to ASTM B117 for 500 hours.
The powder coating is virtually solvent free, and therefore environmentally friendly.

3 High grade & hard anodised aluminium pinion

Actuators with high grade & hard anodised aluminium pinions, passed a 500 hours salt spray test. Optional stainless steel pinions are available for a higher corrosion resistance.

4 Stainless steel or Deltatone treated external steel parts

External parts are stainless steel or steel alloy with a Deltatone® treatment.

Technical data

Coating	: Polyester non-TGIC based powder coating
Salt spray test	: DIN 50021 / ASTM B117: 500 hours
Color	: Yellow (RAL 1007)
Materials	: Housing : Aluminium alloy
	: Pinion : High grade aluminium alloy, hard anodised (Option : Stainless steel)
	: Fasteners : Stainless steel or alloy steel with Deltatone® treatment
	: Tagplate : Stainless steel
Application	: Standard EL-O-MATIC E & P series pneumatic actuators For Non-Standard actuators, see data sheet 4.204.05
Option	: CSR coating for excellent corrosion resistance See data sheet A4.204.02

**High grade aluminium alloy,
hard anodised**

(Option : Stainless steel)

Stainless steel fasteners

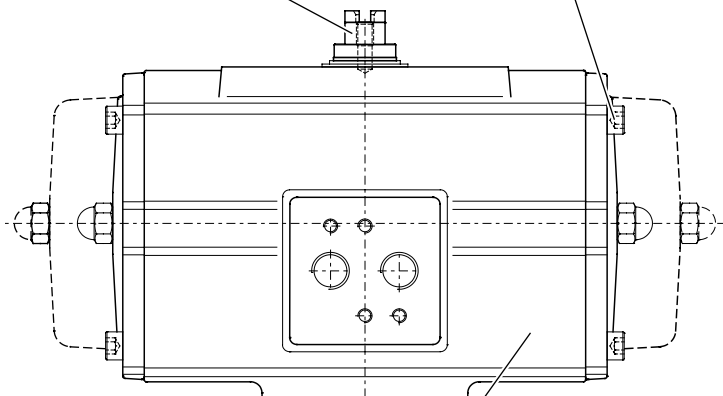

Powder coating:

Polyester non-TGIC based powder coating for exterior use

EL-O-MATIC™

www.El-O-matic.com

Copyright © Emerson Process Management. The information in this document is subject to change without notice.

Updated data sheets can be obtained from our website www.El-O-Matic.com or from your nearest Valve Automation Center **USA:** +1 281 477 4100 **Europe:** +31 74 256 10 10 **Asia-Pacific:** +65 6501 4600



EMERSON™
Process Management

Data sheet

Sheet No.: A4.204.02 Rev. B

Date: June 2009

EL-O-MATIC ACTUATOR WITH CSR COATING

CSR

Hard anodised aluminium
(Option : Stainless steel)

Stainless steel fasteners

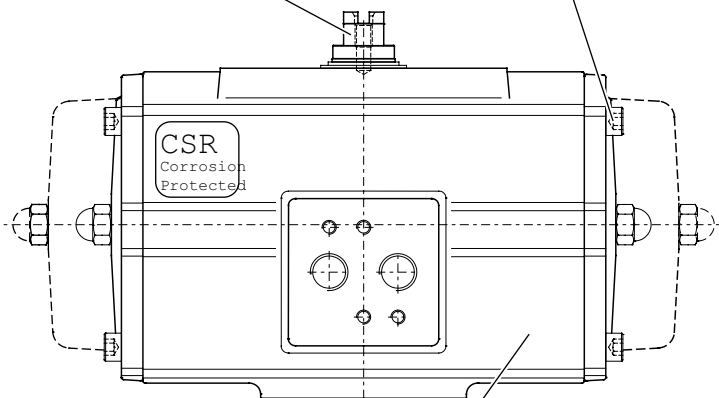

Coating:

20 microns Ceramic filled epoxy resin

Description

EL-O-MATIC CSR-actuators have an excellent corrosion resistance in environments where the actuator is in contact with chemicals like caustic soda. The CSR coating itself is resistant to at least 1000 hours of salt spray test exposure. Together with the excellent mechanical properties, the CSR coating is "the" solution for very harsh environments

CSR actuator housing and caps are completely coated (inside and out) with a ceramic filled fluoropolymer based epoxy resin, impregnated by a temperature of 240°C into the aluminium surface.

Approximately 40% of the coating is impregnated into the aluminium, 60% stays on the surface of the component as a seal.

Technical data

Coating	: Ceramic filled fluoropolymer based epoxy resin
Layer thickness	: 20 microns
Salt spray test	: DIN 50021 / ASTM B117: 1000 hours
Max. temperature	: -4° to 176°F (20° to + 80°C)
Materials	: Housing : Aluminium alloy
	: Shaft : Aluminium hard anodised
	: (Option : Stainless steel)
	: Fasteners : Stainless steel
	: Tagplate : Stainless steel
Application	: Optional on all EL-O-MATIC actuators

Chemical resistances

Resistance to various inorganic chemicals, organic chemicals, gasolines, oils, detergents, etc. is generally good to excellent, but also depends on temperature and/or concentration. More detailed information available at data sheet A4.204.021

EL-O-MATIC™

www.El-O-matic.com

Copyright © Emerson Process Management. The information in this document is subject to change without notice.

Updated data sheets can be obtained from our website www.El-O-Matic.com or from your nearest Valve Automation Center **USA:** +1 281 477 4100 **Europe:** +31 74 256 10 10 **Asia-Pacific:** +65 6501 4600



EMERSON™
Process Management

Data sheet

Sheet No.: A4.204.021 Rev. A

Date: November 2009

CHEMICAL RESISTANCE LIST FOR CSR COATING

CSR

Inorganic chemicals

1	Ammonium hydroxide (10%)	2
1	Calcium chloride (~50%)	3
3	Chlorine	1
3	Chromic acid	1
3	Hydrofluoric acid (50%)	1
1	Caustic potash solution (10%)	3
1	Sodium hypochlorite (saturated)	2
1	Caustic soda solution (10%)	1
1	Caustic soda solution (saturated)	2
1	Phosphoric acid (10%)	1
1	Phosphoric acid (50%)	

Organic chemicals

3	Acetone	1	Glycerine
3	Acetonitrile	1	Hexane
3	Aniline	1	Isooctane
2	Benzene	1	Isopropanol
1	n-Butanol	1	Methanol
3	Butyl acetate	3	Methylene chloride
3	Chlorobenzene	3	Methyl ethyl ketone
3	Chloroforme	3	N,N-Dimethylformamide
3	o-Chlorophenol	3	N-Methylpyrrolidon
1	Cyclohexane	1	Oxalic acid
3	Cyclohexanone	1	Perchloroethylene
3	1,2-Dichloroethane	1	Petroleum ether
2	Diethyl ether	3	Phenol
2	Dioxane	1	Carbon bisulphide
1	Glacial acetic acid	1	Turpentine
1	Ethanol	2	Tetrachloroethane
3	Ethyl acetate	2	1,1,1-Trichloroethane
1	Ethylene glycol	1	Tetrachloromethane
1	Formaldehyde	3	Trichloroethylene
2	Freon 11	2	Toluene
2	Freon 22	1	Xylene

1 Excellent
2 Limited resistance; it is recommended to perform field tests under the specified conditions.
3 Not recommended

Fuels/lubricants

1	Two-star petrol (50°C)
1	Four-star petrol (50°C)
1	Fuel M 15 (50°C)
1	Diesel oil
1	Kerosene
1 to 2	Hypoid bevel gear oil Shell Spirax HD 90 (150°C)
1	Transmission oil Shell Spirax MA 80 (150°C)

Chemicals

1	Automatic transmission fluid Shell Dextra 11D 20-137 (150°C)
1	Engine oil, mineral, Mihag 1500-40 (150°C)
1	Engine oil, synthetic, Mobil SHC 10 W-40
3	Brake fluid Hydraulan DOT 4
1	Roller bearing grease DIN 51 825

Technical detergents

2	Genkeene
2	1,1,1- Trichloroethane
2	Triklone A
2	Perchloroethylene

Miscellaneous fluids

1	Glystantin (BASF)/water
1	Plasticizer DOP
1	Suds
1	Washing-up liquids
1	Household detergents
1	Linseed oil
1	Milk
1	Soapsuds
1	Silicone oils

Note: This list has been composed with great care. However, EL-O-MATIC cannot be held responsible, either for any errors in this list or for their consequences.

Because of continued testing this list is subject to change without notice.

EL-O-MATIC™

www.El-O-matic.com

Copyright © Emerson Process Management. The information in this document is subject to change without notice.

Updated data sheets can be obtained from our website www.El-O-Matic.com or from your nearest Valve Automation Center **USA:** +1 281 477 4100 **Europe:** +31 74 256 10 10 **Asia-Pacific:** +65 6501 4600



EMERSON™
Process Management

Data sheet

Sheet No.: A1.203.011 Rev. A

Date: November 2009

DIMENSION SHEET STANDARD 180° ACTUATOR

180°

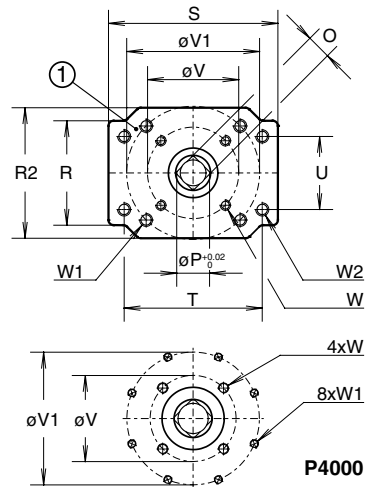
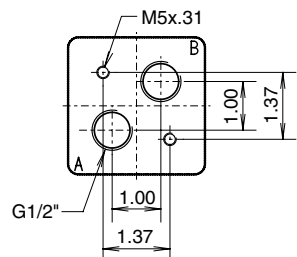
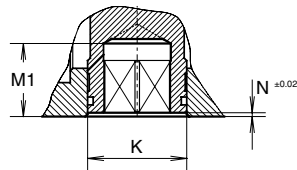
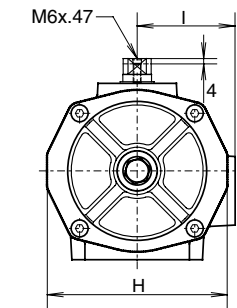
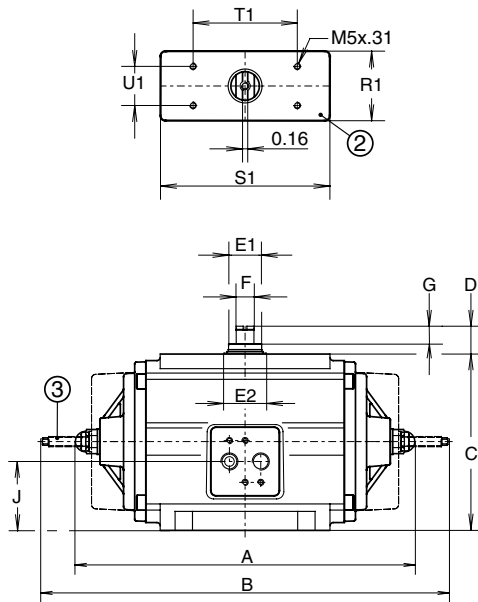
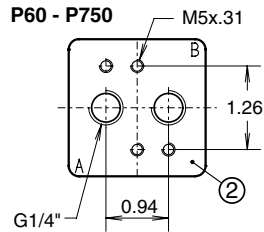

Dim. in mm.	ACTUATOR TYPE								
	E12	P60	P150	P280	P500	P750	P1100	P2500	P4000
A DA		9.17	11.61	13.94	16.30	17.60	19.76	24.92	29.61
B SR		10.08	13.07	17.09	19.57	21.77	25.24	32.17	42.95
C		3.98	5.31	6.30	7.48	9.21	9.72	14.02	14.96
D		0.79	0.79	0.79	1.18	1.18	1.18	1.18	1.18
E1		0.63	0.87	1.02	1.42	1.42	1.77	2.17	2.52
E2		0.91	1.18	1.38	1.77	1.77	2.17	2.56	3.15
F		0.39	0.55	0.55	0.75	0.75	1.18	1.42	1.42
G		0.47	0.47	0.47	0.75	0.75	0.39	0.39	0.39
H		3.98	5.43	6.61	7.56	9.41	9.84	13.54	14.65
I		2.28	2.95	3.50	4.29	5.28	5.31	7.20	7.87
J		1.69	2.09	2.72	3.74	4.57	4.92	7.01	7.48
K		1.10	1.50	1.89	2.20	2.20	2.95	3.35	4.72
M1		1.06	1.06	1.22	1.50	1.50	2.01	2.60	3.03
N		0.04	0.04	0.06	0.06	0.08	0.10	0.12	0.06
O max.		0.556	0.674	0.871	1.068	1.068	1.424	1.817	2.173
O min.		0.551	0.669	0.866	1.063	1.063	1.417	1.811	2.165
P		0.713	0.992	1.110	1.425	1.425	1.898	2.370	2.843
R		2.36	3.15	3.98	4.37	5.51	5.51	6.69	6.69
R1		2.01	2.36	2.80	3.19	3.94	4.72	6.30	6.30
R2		2.76	3.94	-	-	-	-	-	10.31
S		4.37	5.12	5.55	6.34	8.27	8.27	11.42	11.42
S1		4.37	5.12	5.55	5.55	6.30	8.27	9.65	9.65
T		-	-	-	-	-	-	9.24	-
T1		3.15	3.15	3.15	5.12	5.12	5.12	5.12	5.12
U		-	-	-	-	-	-	3.83	-
U1		1.18	1.18	1.18	1.18	1.18	1.18	1.18	1.18
V		F05	F07	F07	F10	F10	F14	F16	F16
W		1.969	2.756	2.756	4.016	4.016	5.512	6.496	6.496
W1		M6 x .35	M8 x .51	M8 x .51	M10 x .63	M10 x .63	M16 x .79	M20 x1.18	M20 x1.18
W2		F07	F10	F10	F12	F12	-	-	F25
V1		2.756	4.016	4.016	4.921	4.921	-	-	10.000
W1		M8 x .51	M10 x .63	M10 x .63	M12 x .63	M12 x .63	-	-	M16 x 0.98
W2		-	-	-	-	-	-	M16 x 0.98	-

For E12 dimensions see A1.103.102

Note

1. Flange to ISO 5211, square drive to DIN 3337
2. Top and Solenoid flange to VDI/VDE 3845 (NAMUR).
P1100 P2500 and P4000 have a non-NAMUR solenoid flange with 1/2" entries.
3. 180° actuators are standard equipped with "L1" limit stops. 120° or 135° rotation is possible with optional LF-option (See data sheet A1.503.01)



www.El-O-matic.com

Copyright © Emerson Process Management. The information in this document is subject to change without notice.

Updated data sheets can be obtained from our website www.El-O-Matic.com or from your nearest Valve Automation Center **USA:** +1 281 477 4100 **Europe:** +31 74 256 10 10 **Asia-Pacific:** +65 6501 4600



EMERSON
Process Management

Data sheet

Sheet No.: A1.204.01 Rev. C

Date: June 2010

180° DOUBLE ACTING ACTUATOR TORQUE (In.lb.)

180°

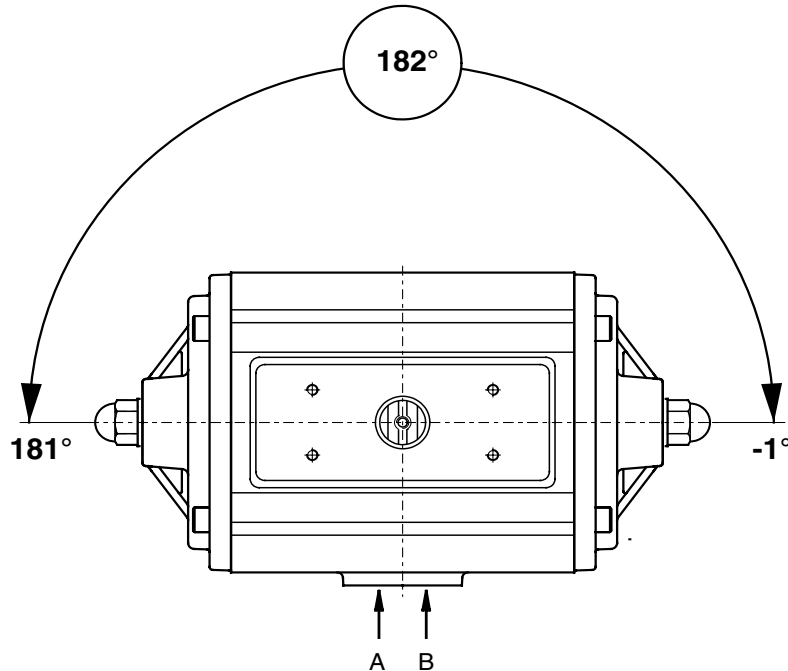
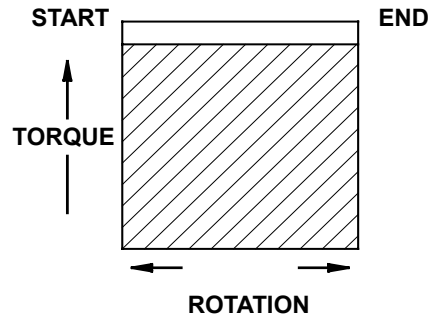

Actuator type	Torque (in in.lb) Supply Pressure (PSI)					
	30	40	50	60	70	80
ED 12	44	59	74	89	104	119
PD 60	104	139	175	210	245	281
PD 150	262	351	441	530	620	709
PD 280	493	662	830	999	1167	1336
PD 500	872	1170	1467	1765	2063	2361
PD 750	1297	1740	2182	2625	3068	3511
PD 1100	1912	2566	3219	3872	4525	5179
PD 2500	4407	5913	7418	8923	10429	11934
PD 4000	7440	9981	12522	15064	17605	20146

Note

- Emerson Process Management recommends that the valve manufacturer supply the maximum required torque values (Including any adjustments or suggested safety factors for valve service conditions or application).
Additionally, the valve manufacturer must identify at which position(s) and direction(s) of rotation (Counter Clock Wise or Clock Wise) these maximum requirements occur.
- If in doubt, or you require any assistance with sizing actuators, do not hesitate to contact your nearest Emerson's Valve Automation Division representative.
- Pressure on port "A" opens the actuator*
- The actuator is shown in closed position*
- Do not exceed the maximum supply pressure of 6 bar / 87psi.
(*code A, data sheet A1.503)

EL-O-MATIC™

www.El-O-matic.com

Copyright © Emerson Process Management. The information in this document is subject to change without notice.

Updated data sheets can be obtained from our website www.El-O-Matic.com or from your nearest Valve Automation Center **USA:** +1 281 477 4100 **Europe:** +31 74 256 10 10 **Asia-Pacific:** +65 6501 4600

EMERSON™
Process Management

Data sheet

Sheet No.: A1.204.02 Rev. C

Date: June 2010

180° SPRING RETURN ACTUATOR TORQUE (In.lb.)

180°

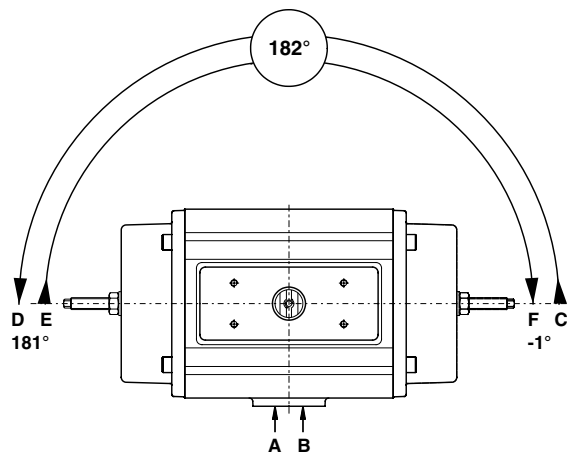
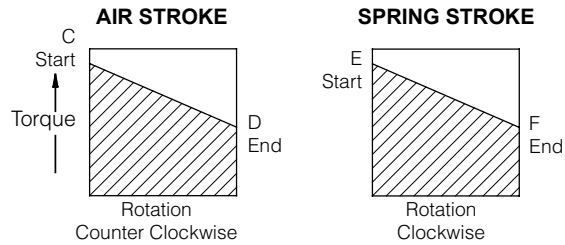

Note

- Emerson Process Management recommends that the valve manufacturer supply the maximum required torque values (Including any adjustments or suggested safety factors for valve service conditions or application). Additionally, the valve manufacturer must identify at which position(s) and direction(s) of rotation (Counter Clock Wise or Clock Wise) these maximum requirements occur.
- If in doubt, or you require any assistance with sizing actuators, do not hesitate to contact your nearest Emerson's Valve Automation Division representative.
- Pressure on port "A" opens the actuator*
- The actuator is shown in closed position*
- Do not exceed the maximum supply pressure of 6 bar / 87psi.
(*code A, data sheet A1.504)

Actuator type	Spring nr.	Air Stroke (in.lb.)										Spring Stroke (in.lb.)	
		SUPPLY PRESSURE (PSI)											
		40		50		60		70		80		E	F
ES12	2	-	-	33	9	49	25	65	41	81	57	63	41
PE60	8	70	19	105	55	141	90	176	125	212	161	112	62
	10	-	-	88	24	123	60	159	95	194	131	141	78
	12	-	-	-	-	106	30	142	65	177	101	169	93
	14	-	-	-	-	-	-	124	35	160	71	197	109
PE150	8	185	76	274	165	364	255	453	344	543	433	258	150
	10	-	-	233	96	322	186	411	275	501	365	322	187
	12	-	-	-	-	280	117	370	206	459	296	387	225
	14	-	-	-	-	239	48	328	137	418	227	451	262
PE280	8	-	-	493	193	662	361	830	530	999	698	597	303
	10	-	-	-	-	578	202	746	370	915	539	746	379
	12	-	-	-	-	-	-	662	211	830	379	896	455
	14	-	-	-	-	-	-	-	-	746	220	1045	531
PE500	8	-	-	965	256	1263	554	1561	852	1859	1149	1134	452
	10	-	-	-	-	1138	251	1435	549	1733	847	1417	565
	12	-	-	-	-	-	-	-	-	1608	544	1701	678
	14	-	-	-	-	-	-	-	-	-	-	1984	791
PE750	8	-	-	1470	549	1913	992	2356	1434	2799	1877	1529	641
	10	-	-	-	-	1735	583	2178	1026	2621	1469	1912	801
	12	-	-	-	-	-	-	2000	618	2443	1060	2294	961
	14	-	-	-	-	-	-	-	-	2265	652	2676	1121
PE1100	8	1454	430	2108	1083	2761	1736	3414	2389	4067	3043	1999	1000
	10	-	-	1830	549	2483	1202	3136	1855	3790	2509	2499	1250
	12	-	-	-	-	2205	668	2858	1321	3512	1975	2999	1500
	14	-	-	-	-	-	-	2581	787	3234	1441	3499	1750
PE2500	8	2625	890	4124	2389	5622	3888	7121	5386	8620	6885	4675	2934
	10	-	-	3309	1140	4807	2639	6306	4137	7804	5636	5844	3668
	12	-	-	2494	-109	3992	1390	5491	2889	6989	4387	7013	4401
	14	-	-	-	-	3177	141	4676	1640	6174	3138	8182	5135
PE4000	8	4475	1548	7015	4088	9555	6628	12096	9169	14636	11709	7890	4952
	10	-	-	5639	1981	8180	4521	10720	7061	13260	9602	9863	6190
	12	-	-	4264	-127	6804	2414	9344	4954	11885	7494	11835	7429
	14	-	-	-	-	5428	306	7969	2847	10509	5387	13808	8667



www.El-O-matic.com

Copyright © Emerson Process Management. The information in this document is subject to change without notice.

Updated data sheets can be obtained from our website www.El-O-Matic.com or from your nearest Valve Automation Center **USA:** +1 281 477 4100 **Europe:** +31 74 256 10 10 **Asia-Pacific:** +65 6501 4600



Contact Us: Emerson Process Management, Valve Automation facilities at your nearest location:

NORTH & SOUTH AMERICA

19200 Northwest Freeway
Houston TX 77065
USA
T +1 281 477 4100
F +1 281 477 2809

2500 Park Avenue West
Mansfield, OH 44906
USA
T +1 419 529 4311
F +1 419 529 3688

13840 Pike Road
Missouri City, Texas 77489
USA
T +1 281 499 1561
F +1 281 499 8445

Av. Hollingsworth,
325, Iporanga Sorocaba,
SP 18087-105
Brazil
T +55 15 3238 3788
F +55 15 3228 3300

MIDDLE EAST & AFRICA

P. O. Box 17033
Dubai
United Arab Emirates
T +971 4 811 8100
F +971 4 886 5465

P. O. Box 105958
Abu Dhabi
United Arab Emirates
T +971 2 697 2000
F +971 2 555 0364

P. O. Box 3911
Al Khobar 31952
Saudi Arabia
T +966 3 814 7560
F +966 3 814 7570

P. O. Box 10305
Jubail 31961
Saudi Arabia
T +966 3 340 8650
F +966 3 340 8790

P. O. Box 32281
Doha
Qatar
T +974 4 576777
F +974 4 315448

24 Angus Crescent
Longmeadow Business Estate East
P.O. Box 6908; Greenstone; 1616
Modderfontein, Extension 5
South Africa
T +27 11 451 3700
F +27 11 451 3800

EUROPE

Asveldweg 11
7556 BR Hengelo (O)
The Netherlands
T +31 74 256 1010
F +31 74 291 0938

Siemensring 112
47877 Willich
Germany
T +49 2154 499 660
F +49 2154 499 6613

25, Rue de Villeneuve
Silic – BP 40434
94583 Rungis
France
T +33 1 49 79 73 00
F +33 1 49 79 73 99

Via Montello 71/73
20038 Seregno (Milan)
Italy
T +39 0362 2285 207
F +39 0362 2436 55

6 Bracken Hill
South West Industrial Estate
Peterlee SR8 2LS
United Kingdom
T +44 191 518 0020
F +44 191 518 0032

2A Szturmowa Str
02-678 Warsaw
Poland
T +48 22 45 89 237
F +48 22 45 89 231

C/ Francisco Gervás, 1
28108 Alcobendas – Madrid
Spain
T +34 0913 586 000
F +34 0913 589 145

Letnikovskaya Str. 10-2
115114 Moscow
Russia and FSU
T +7 495 981 98 11
F +7 495 981 98 10

ASIA PACIFIC

No. 9 Gul Road
#01-02 Singapore 629361
T +65 6501 4600
F +65 6268 0028

9/F Gateway Building
No. 10 Ya Bao Road
Chaoyang District
Beijing 100020
P.R.China
T +86 10 8572 6666
F +86 10 8572 6888

No.1 Lai Yuan Road
Wuqing Development Area
Tianjin 301700
P.R.China
T +86 22 8212 3300
F +86 22 8212 3308

Lot 13112, Mukim Labu
Kawasan Perindustrian Nilai
71807 Nilai, Negeri Sembilan
Malaysia
T +60 6 799 2323
F +60 6 799 9942

471 Mountain Highway
Bayswater, Victoria 3153
Australia
T +61 3 9721 0200
F +61 3 9720 0588

Delphi B Wing, 601 & 602
6th Floor, Central Avenue
Powai, Mumbai – 400 076
India
T +91 22 6662 0566
F +91 22 6662 0500

© 2013 Emerson Process Management. All rights reserved.

The Emerson logo is a trademark and service mark of Emerson Electric Co. "Brand mark listing" are marks of one of the Emerson Process Management family of companies.

All other marks are property of their respective owners.

The contents of this publication are presented for information purposes only, and while every effort has been made to ensure their accuracy, they are not to be construed as warranties or guarantees, express or implied, regarding the products or services described herein or their use or applicability. All sales are governed by our terms and conditions, which are available on request. We reserve the right to modify or improve the designs or specifications of our products at any time without notice.

EL-O-MATIC® is a registered trademark of EL-O-MATIC B.V.

EL-O-MATIC™

www.El-O-matic.com



EMERSON™
Process Management